

This drawing is the Property of METAL FAB INDUSTRIES LTD. All dimensions are outside/outside unless otherwise stated

Item Number	Document Number	Title	Material	Quantity
1*	APL00025	APOLLO BASE	Zintec 1.6mm	1
2	APLAC021	APL PEDISTAL HIGH ASSEMBLY		1
3	APL00130	APL BODY MOUNT BRACKET	3mm COLD ROLL	4
4	APLAC004	APL FIREBOX ASSEMBLY		1
5	APL00010	APL SIDE PANEL ANGLE R/H	10mm ZINTEC	1
6	APL00009	APL L/H SIDE PANEL ANGLE	ZINTEC 1.0MM	1
7	APL00038	APL HEAT SHIELD	ZINTEC	1
8	APL00036	APL AIR SLIDE	COLDROLL	1
9	MIC00740	LOGAIRE BADGE	CAST	1
10	MICAC190	MICROS DOOR HINGE ASSMBLY		1
11*	APLAC030	APL DOOR ASSEMBLY		1
12	APLAC034	APL GLASS RETAINER ASSEMBLY		1
13	APL00743	APL GRATE	Cast Iron	1
14	APL00154	APL ASH TRAY	1.2mm COLDROLL	1
15	APL00110	APL BAFFLE DRY	6mm HOTROLL	1
16	APL00017	APL LOUVRE	Enamel	6
17	APL00016	APL AIR SLIDE COVER	1.2 COLDROLL	1
18	APL00006	APL L/H SIDE PANEL	ENAMEL 1.2MM	1
19	APL00006	APL L/H SIDE PANEL	ENAMEL 1.2MM	1
20	APL00012	APL REAR PANEL	ZINTEC	1
21	APL00003	APL GRILL PANEL	ENAMEL	1
22	MICAC373	MIC DOOR SPINDLE ASSEMBLY		1
23*	FLUE PIPE	FLUE PIPE		1

PART NUMBER : APL ASSY

REVISION LEVEL :

Amendment	Date	By

Tolerances Unless Specified
 Decimal Places 0 +/- 0.5
 0.0 +/- 0.1
 0.00 +/- 0.05

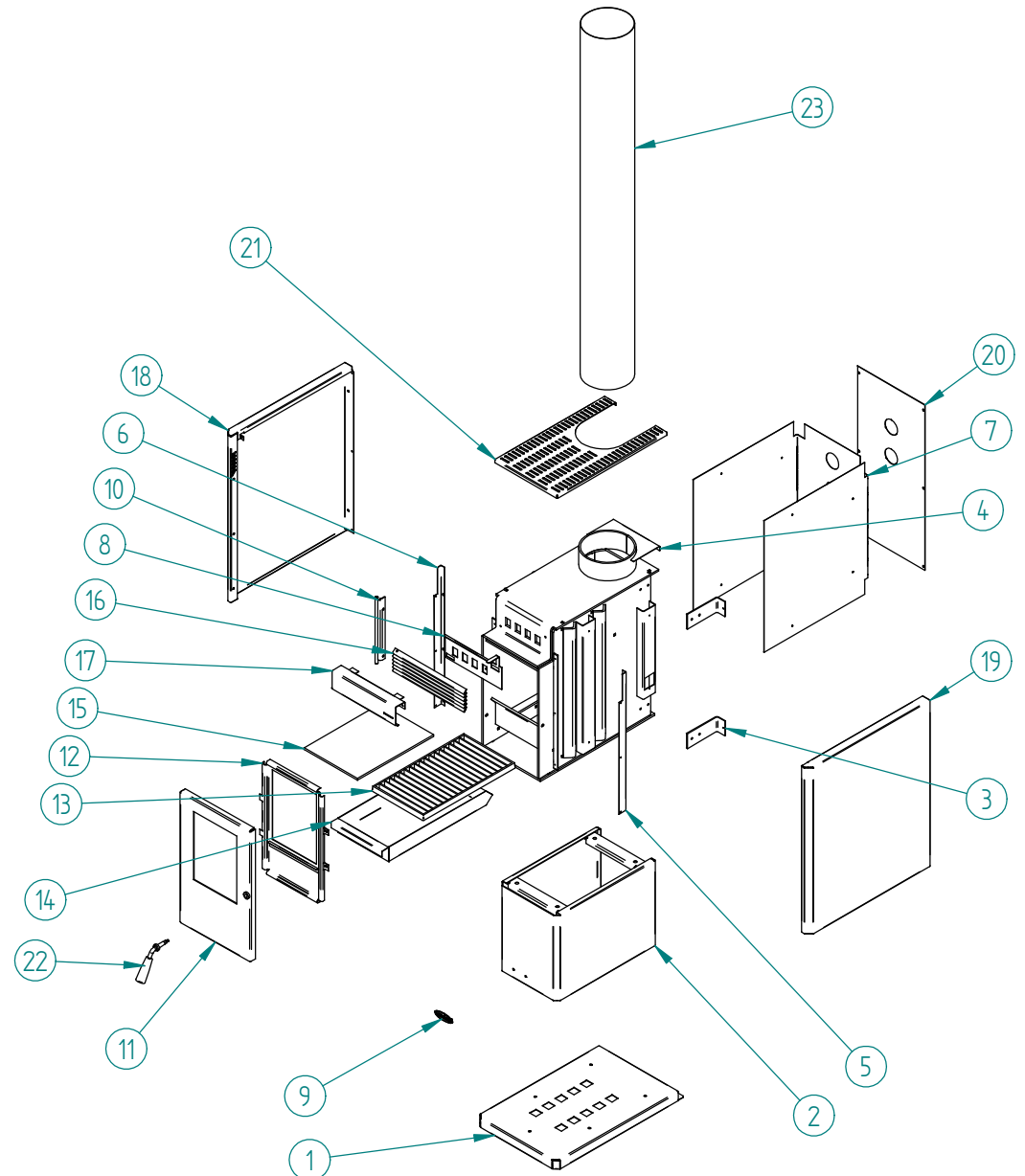

Weight = 0.000 kg

METAL FAB INDUSTRIES LTD
 38 HARRIS ROAD, EAST TAMAKI, AUCKLAND, NEW ZEALAND
 Ph 09 274 8265, Fax 09 274 8472, Email : engdept@metalfab.co.nz

Customer : LOGAIRE	Drawing No:	Date : 29/06/05	Drawn By: LeonK	Checked By :
Part Name : APL ASSEMBLY		Material :	Finish : Natural	