

# escea.

IB1100, IB850, IB600

## Installation Manual

NEW ZEALAND EDITION

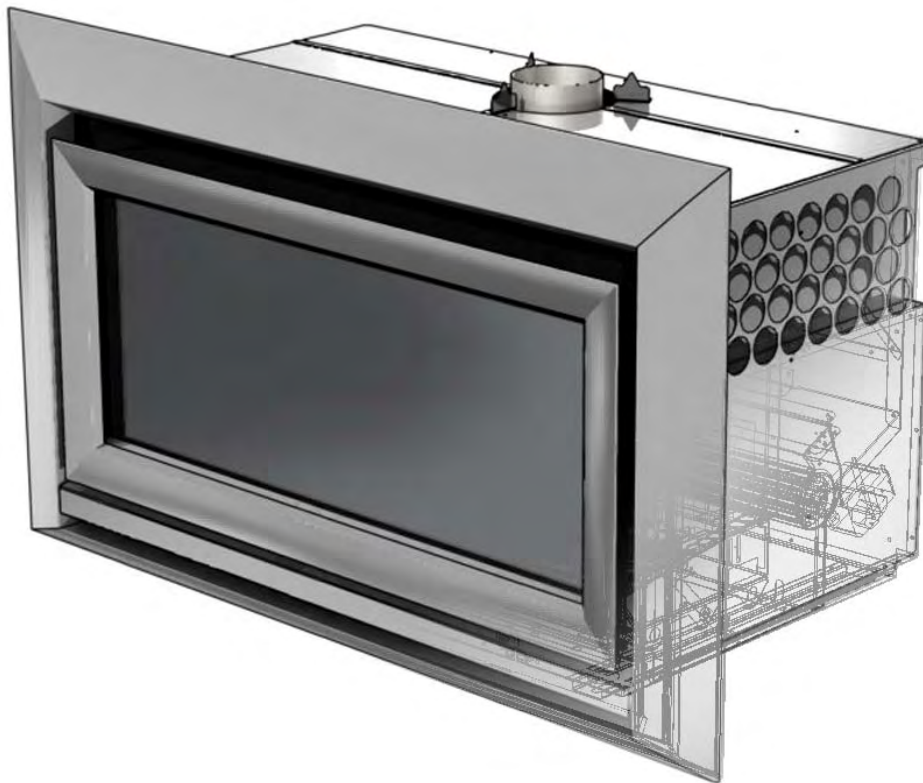

### Important

The appliance shall be installed in accordance with;

- This installation instruction booklet
- Local gas fitting regulations
- Municipal building codes
- Electrical wiring regulations
- AS 5601 / AG 601—2000, *Gas installations* / NZ5261:2003 *Gas Installation*
- Any other relevant statutory regulations.
- Must be installed by a qualified person

*This appliance is not intended for use by young children or infirm persons unless they have been adequately supervised by a responsible person to ensure that they can use the appliance safely.*

*Young children should be supervised to ensure that they do not play with the appliance.*

Manufactured by: Escea Ltd, PO Box 5277 Dunedin NZ, Ph: +64 3 479 0302, email: [info@escea.net](mailto:info@escea.net)  
For contact details of your local escea distributor or dealer please visit [www.escea.net](http://www.escea.net)

## Note:

### THERE ARE FIVE MAIN THINGS TO CONSIDER BEFORE INSTALLATION

- Cavity Dimensions & Clearances
- Coupling of Flue to Fire
- Coupling of Gas Lines to Fire
- Supply of Electricity to Fire
- Fixing the Fire to the Cavity

The sequences you choose to do these tasks will vary on your individual scenario. Please read these instructions fully before proceeding with your installation.

Leave the installation of the fascia panels until the very end of the installation and commissioning to avoid damage to the fascia panels.

### **WARNING:**

**Failure to follow these instructions could cause a malfunction of the heater, which could result in death, serious bodily injury, and/or property damage. Failure to follow these instructions may also void your fire insurance and/or warranty.**

### **Installation:**

Installation must be carried out by a registered installer who, on completion of the installation, must issue a certificate of compliance, in accordance with national and/or local codes. If a certificate of compliance is not issued then the Escea warranty *may* be void.

This appliance needs fresh air for safe operation and must be installed with provisions for adequate combustion and ventilation air available to the room in which it is to be operating.

### **Warranty Repair and Annual Servicing:**

Warranty repair work must be carried out by a recognised Escea gas fire technician. It is recommended that recognised Escea Gas fire technicians are also used to carry out annual servicing requirements (particularly during the warranty period). For contact details of authorised Escea technicians in your area, please contact the retailer from whom the appliance was purchased.

The heater must be installed according to these instructions and in compliance with all relevant building, gas fitting, electrical and other statutory regulations (eg. AS 5601 (AG-601), NZ5261). Any shortcomings in the appliance and flue installation will be the responsibility of the installer, and Escea will not be accountable for any such failings or their consequences.

**Contents:****Section:**

• Product Description _____	1.0
• Creating the Cavity _____	2.0
• Ventilation _____	3.0
• Cavity Base _____	4.0
• Hearth _____	5.0
• Raised Installations Up a Wall _____	6.0
• Wall Linings _____	7.0
• Mantle Clearance _____	8.0
• Television Clearance _____	8.1
• Corner Installations _____	9.0
• Power Supply _____	10.0
• Installing the Flue System _____	11.0
• Flue Assembly _____	12.0
• Masonry Cavity and Chimney _____	13.0
• Laying Gas Pipe _____	14.0
• Assembling the Zero Clearance Kit _____	15.0
• Fixing the Zero Clearance Kit to the Cavity _____	16.0
• Gas Fireplace Installation _____	17.0
• Attaching the Flue to the Fireplace _____	18.0
• Connecting the Gas Pipe _____	19.0
• Fixing the Heater to the Base and Wall _____	20.0
• Locating the Log Set _____	21.0
• Electrode Placement _____	22.0
• Checking Operating Pressure _____	23.0
• Fitting the Fascia Panels _____	24.0
• Locating Wall Mount Cradle for Wireless Control _____	25.0
• Normal Operating Sounds and Smells _____	26.0
• Installation Check List _____	27.0

1.0 **Product Description:**

The Escea IB1100, IB850 and IB600 gas fires are designed to be built into a cavity. These appliances are flued conventionally via Ø100mm flue system.

The Escea IB600 Zero Clearance Kit , IB850 Zero Clearance Kit and IB1100 Zero Clearance Kit are to be used for all installations. They seal the cavity and isolate the fire from air pressure changes within the cavity.

The only instance that the ZCK might **not** be fitted is in a New Zealand installation within a full masonry chimney that is not open to any other building space. If the top of the chimney is not present and the cavity is open to the roof space then a ZCK must be used.

The user will control their fire with the Radio Frequency (RF) remote that will normally be left in its wall mount cradle. In addition to the RF remote it has a single auxiliary On/Off button on the unit. When not in operation it is in a standby mode unless it is physically isolated from the mains supply.

1.1 Zero Clearance Kit (ZCK) Dimensions

**IB850 & IB1100**

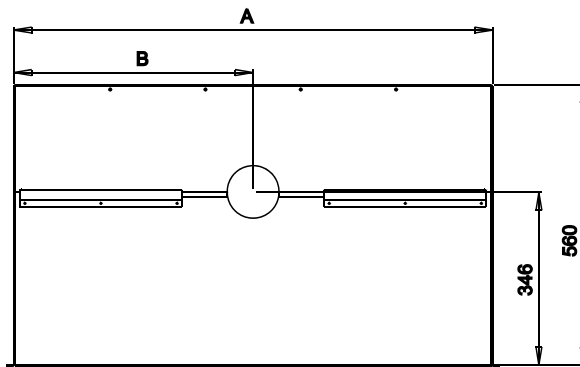

	A	B
<b>IB850</b>	960mm	480mm
<b>IB1100</b>	1260mm	630mm

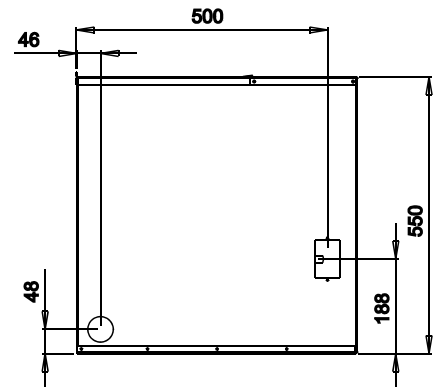
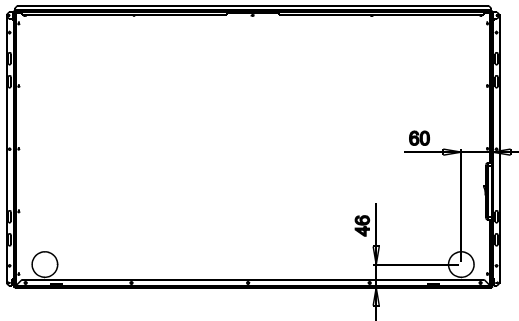

**IB600**

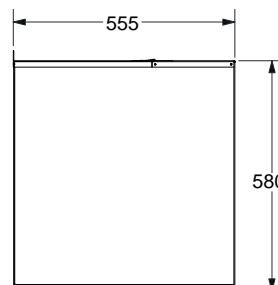
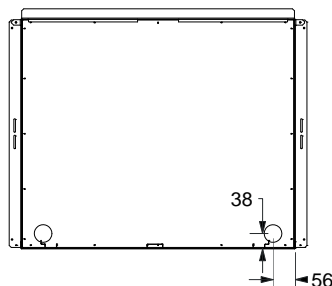
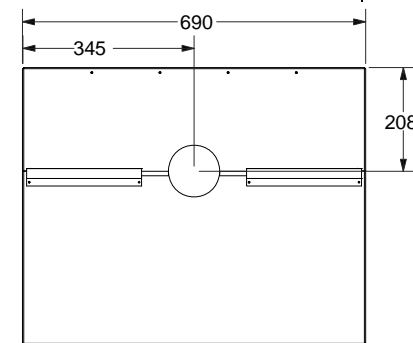

1.2 Product Dimensions

**IB600**

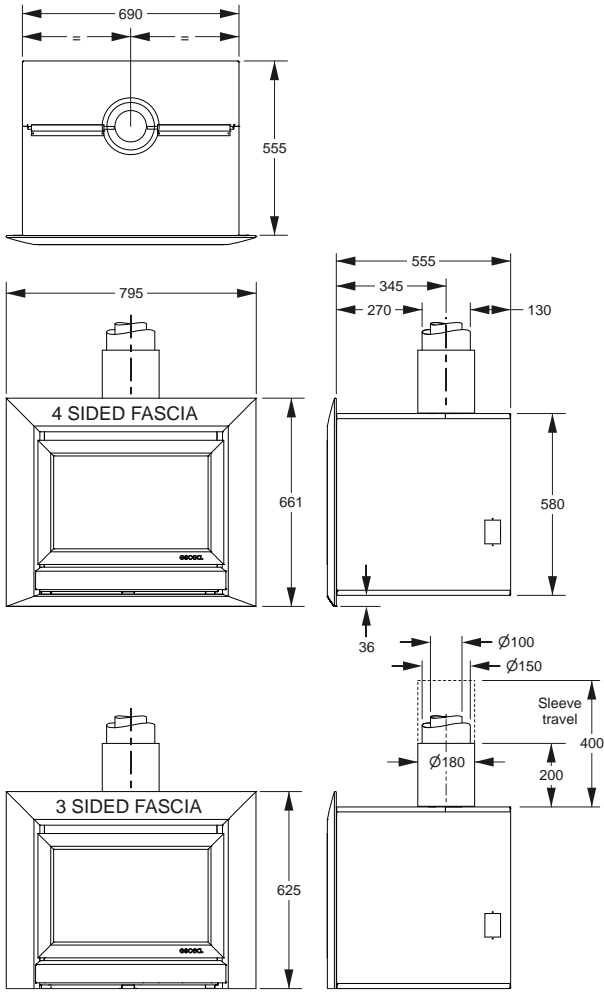

**IB850**

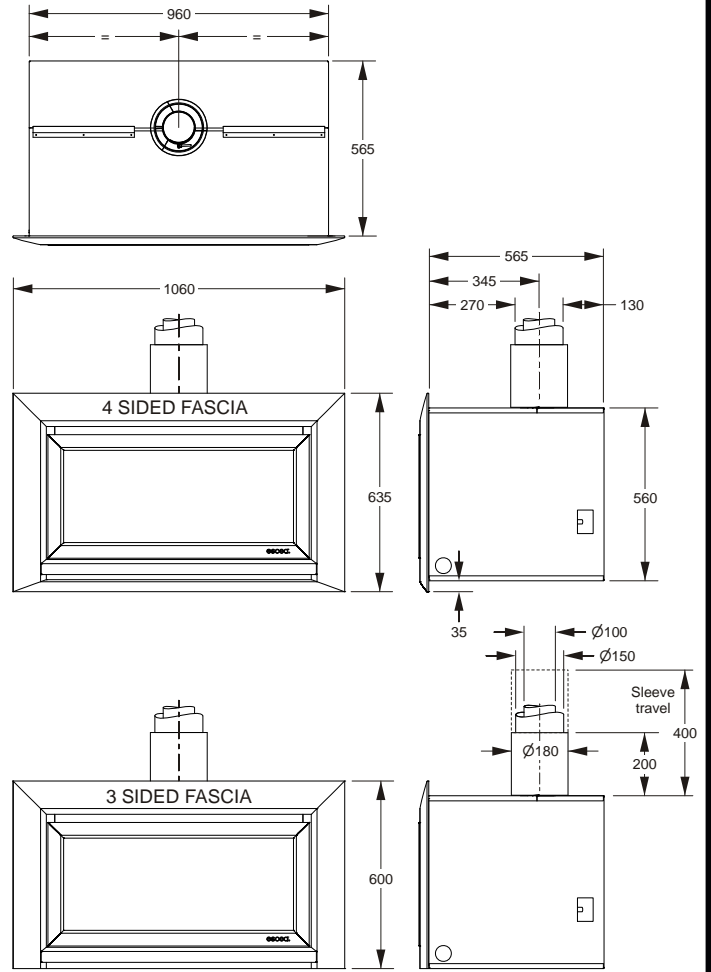

# IB1100

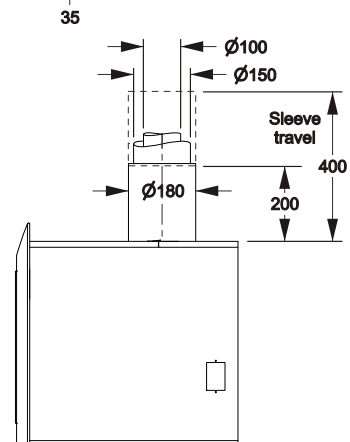
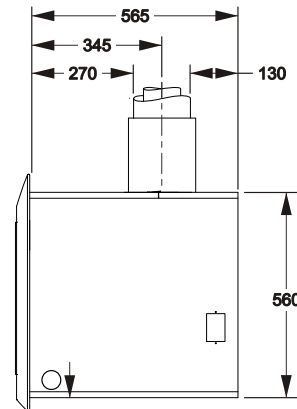
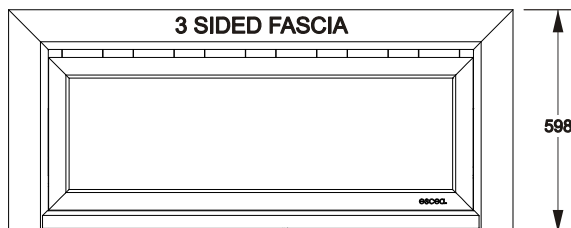
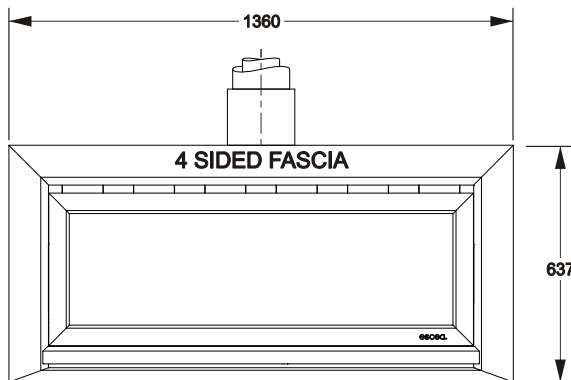
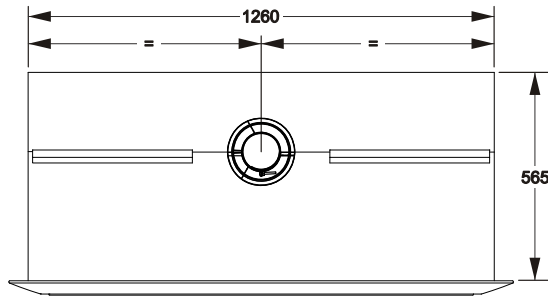

## 2.0 Creating the Cavity:

The dimensioned drawing below shows the size of the opening that must be created to keep combustible materials at the required distance from the heater.

Note: It is not necessary to line the side, top or back of the cavity.

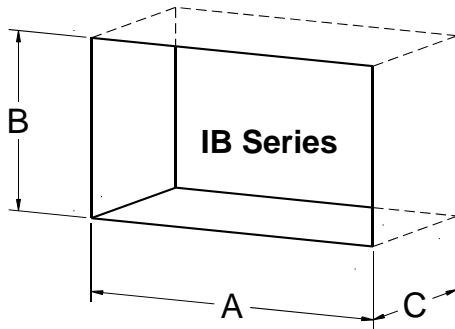

### Ideal Cavity Dimensions:

All dimensions in millimetres

	A	B	C
<b>IB600</b>	695	590	565
<b>IB850</b>	960	560	565
<b>IB1100</b>	1260	560	565

(Check offset. Refer 2.2)

- 2.1 Where possible, it is recommended that cavity is made slightly larger than the above dimensions to give the installer the maximum amount of space to work in.
- 2.2 The IB1100 and IB850 have their electronics compartment protruding from the left hand side of the fire and the resulting offset needs to be taken into account when installing into a tight masonry cavity.

## 3.0 Ventilation

It is **important to remember** that Clause G4.2.0 of the New Zealand Building Code and Section 2.6.6 of the New Zealand Gas Installation Standard calls for additional ventilation into living spaces where open flued natural draught appliances are installed.

Both of these codes provide formulae and tables for calculating the required ventilation given the size of the living space and the gas input of the appliance.

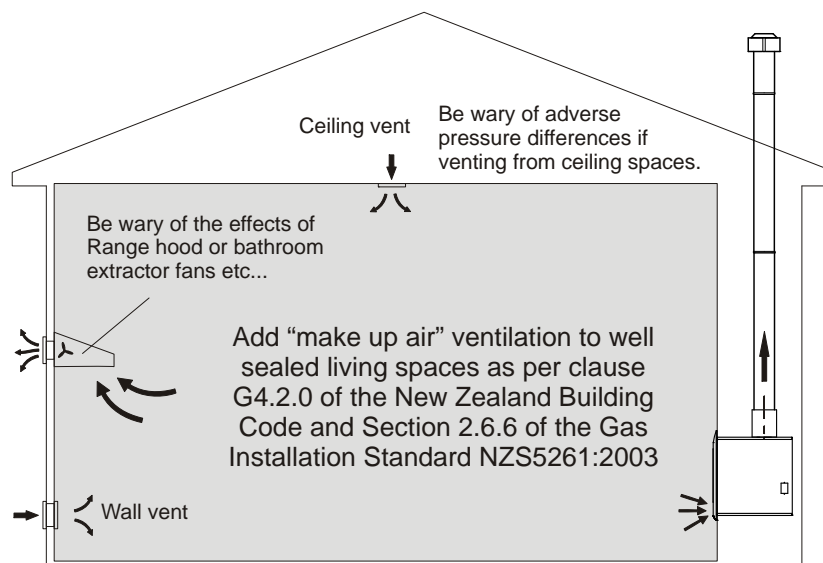

## 4.0 Cavity Base:

This appliance **MUST** be fully supported on its base. The base must extend over the entire area of the underside of the appliance. The base must also be levelled to prevent vibration

from possible fan imbalance. For the installation of an IB1100 the base of the cavity must be strong enough to support the total product weight, which is a minimum of 70kg

The base of the product must be fully supported at either side and at the centre front to back.

#### 5.0 **Hearth:**

If this fire is being installed at floor level a hearth made from non-combustible material must extend *no less than 300mm from the front of the fire*. This hearth should be at least as wide as the fire's outer fascia and no less than 10mm thick. Raised hearths can be any size but must also be constructed from non combustible materials.

5.1 The floor in front of this hearth will still get warm so if the floor covering is vinyl, nylon carpet or another heat sensitive material then we recommend extending the hearth to 450mm from the fire.

5.2 **NOTE:** If the hearth is to be covered with tiles or some other veneer then the fire must be installed so that the base of the 'Zero Clearance Kit' is level with the finished top surface of the hearth.

#### 6.0 **Raised Installations Up a Wall:**

If the fire is being located in such a way that the bottom of the cavity is any more than **100mm** up off the ground no hearth is required. Escea recommend that if a heater is being mounted more than 100mm up a blank wall and no hearth is being used, then a **four sided fascia** is used (available from your Escea dealer).

7.0 **Wall Linings:** The front mounting flanges of the 'Zero Clearance Kit' **MUST** be on top of the **FINISHED** wall surface in order for the fascia panels to mount properly. Take into account any plaster board, tiles or any other finishing surface that may be intended for the finished wall surface. Wall finishing materials must not encroach upon the minimum cavity clearances given in section 1.0. The wall board that lines the outside of this opening can be normal dry wall (plaster board) and does not need to be non-combustible.

**Note:** The temperature of the wall lining directly above the heater does get warm and hence may discolour paint finishes that are susceptible to temperature damage or distort vinyl wall coverings. For durability of finishes and surfaces you should contact the relevant manufacturer for their specification.

#### 8.0 **Mantle Clearance:**

Please refer to the diagram to the right. Mantles or protruding ledges mounted above the heater that are made from combustible materials, must not extend outside of the dimensions shown.

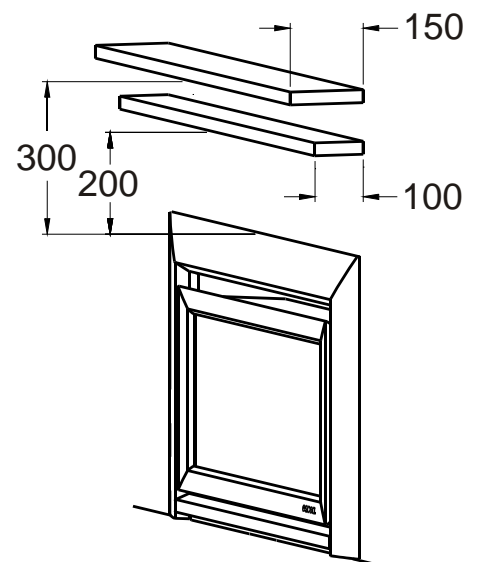

### 8.1 Television Clearances:

The following are the recommended minimum clearances for the location of any electrical equipment (such as Plasma TV, LCD TV or home theatre) above an Escea IB Series gas fire. Use either a shelf or mantle below your TV screen or alternatively you can construct a recess to mount your TV screen into.

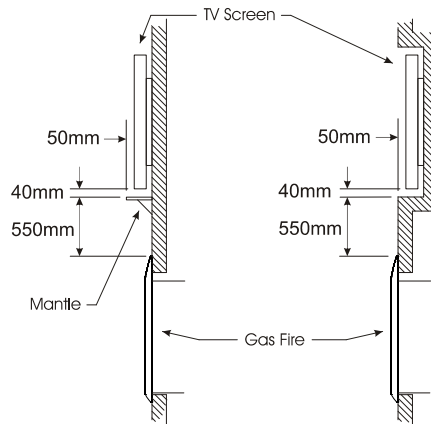

**Note:** The above television clearance recommendations are to be treated as a suggestion of a suitable installation only. It is the responsibility of the end user to check the installation instructions of their electrical appliances to ensure that the location in relation to the gas fire is suitable. Escea in no way guarantees or takes responsibility that the above installation suggestion will be suitable for all electrical or home entertainment appliances.

### 9.0 Corner Installations:

If a cavity is to be created in a corner, the following drawings give the minimum sized interior wall and resultant flue position.

#### 9.1 Minimum corner install dimensions:

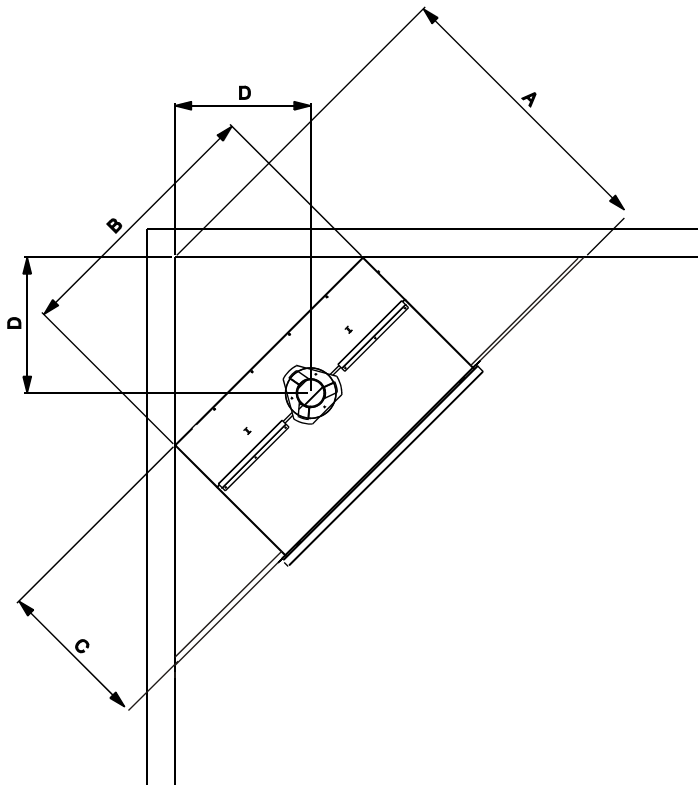

	<b>IB1100</b>	<b>IB850</b>	<b>IB600</b>
<b>A</b>	1200	1040	900
<b>B</b>	1265	965	690
<b>C</b>	560	560	555
<b>D</b>	600	490	391

### 10.0 Power Supply:

Whilst the cavity is being created consideration should be given to appropriate location of a standard 3 pin, EARTHED 240V power outlet. This must be within **0.5m** of the rear left hand corner of the appliance.

10.1 Locating the power outlet within the cavity makes the installation very neat but the provision **MUST** be made to be able to switch the power supply off and on (electrical isolation switch) and **MUST** be accessible after the heater has been installed. This is normally done by means of a separate switch located outside of the cavity and wired to the plug. This will allow service technicians to isolate the power supply before performing service work on the appliance.

10.2 This appliance will draw a maximum of 1.2 Amps from a 240V supply. No additional power supply is required for power flue installations and no telephone wiring is needed for the i-con phone switch

The electrical cord (from an extension cord) should pass through the Outer Skin Kit as shown, through the supplied Cord Strain Relief Bush.

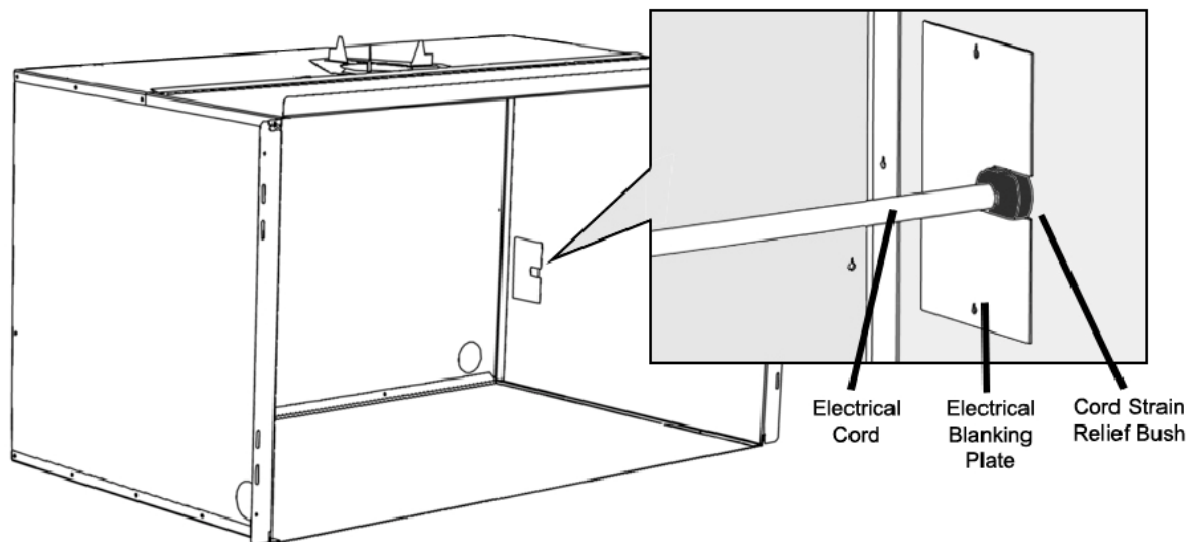

**11.0 Installing the Flue System:**

Non-Masonry Timber Frame Cavity:

The heater must be flued to the outside via a 100mm diameter stainless steel flue that is covered by a 150mm diameter liner. This must be installed in accordance with the requirements of AS5601 / NZ5261.

The minimum flue length = 3.6m vertical height

It is important to check that you have all the necessary flue parts before beginning your installation.

A standard timber flue installation should include the following components:

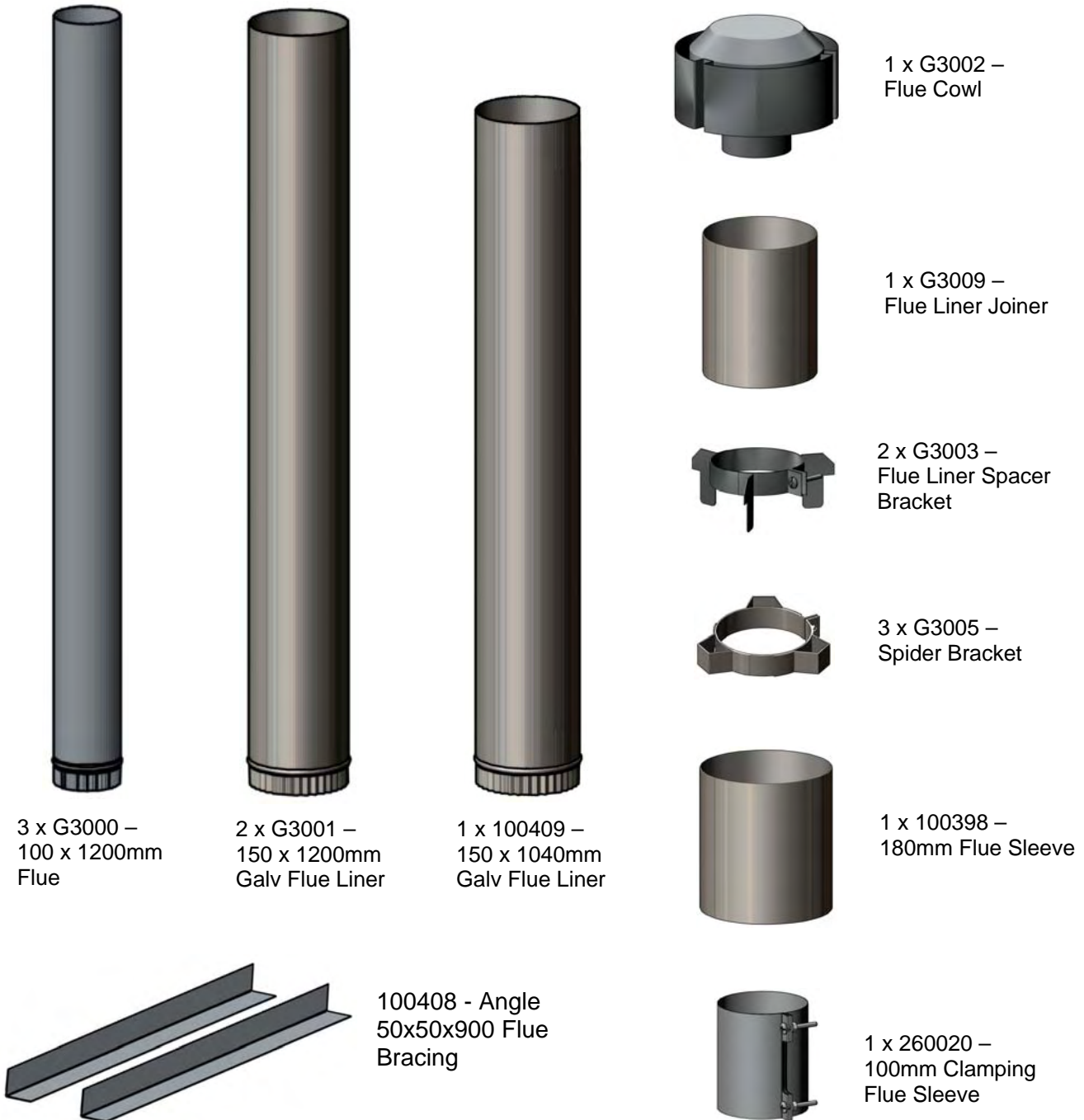

## 12.0 Flue Assembly

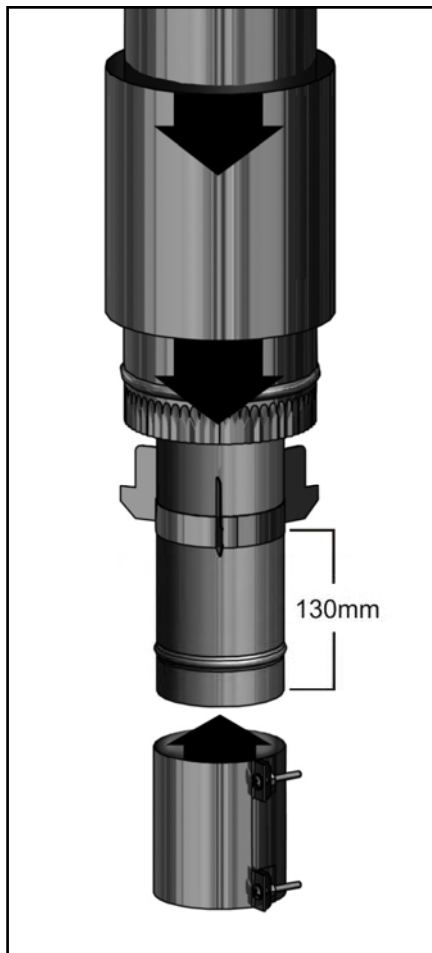
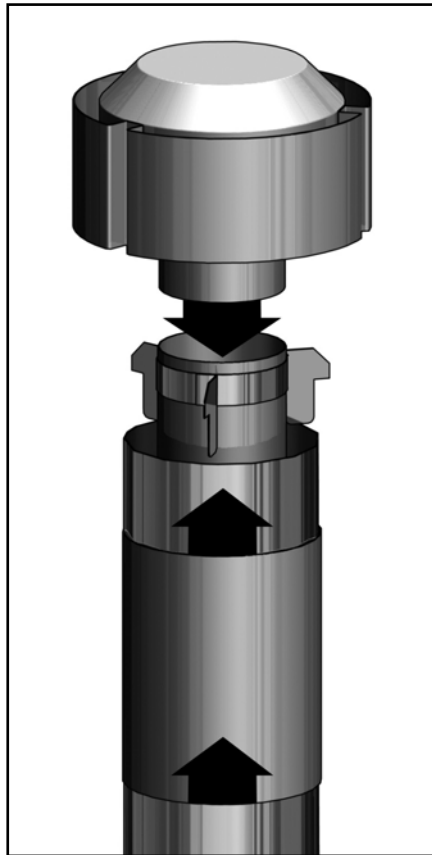

Secure the Flue spacer bracket (G3003) to the top section of 100mm Flue and insert the cowl, this can be riveted or held in place with screws (see 10.1 Installing the Flue Terminal). Now slide the 150mm flue onto the bracket.

For each section of flue a Spider bracket will be required. These act as spacers for the 150mm flue and should be attached half way along each section of flue.

The bottom section is similar to the top assembly. The flue spacer bracket must be secured 130mm from the end of the 100mm flue, this will give clearance to slide the flue sleeve up the flue when installing the Fireplace. Once the installation is complete the 180mm flue sleeve can be slid down to cover and protect the lower assembly.

## 12.1 Installing the Flue Terminal

Cut the flue termination to the height specified on the attached "Flue position" diagrams and leave a vertical offset of 20 - 30mm between the inner and outer as shown. Slide the flue liner sleeve over the liner and push it down about 150mm out of the way. Fit the flue spacer bracket between the flue and flue liner.

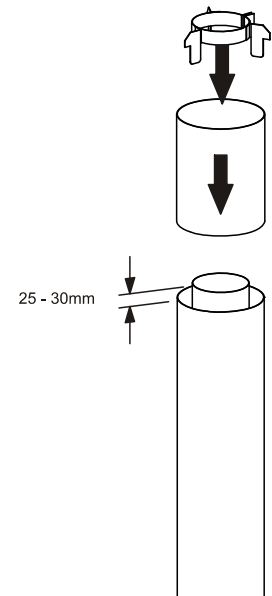

Cut & bend an 80mm by 100mm flap and bend towards the inner flue as shown below.

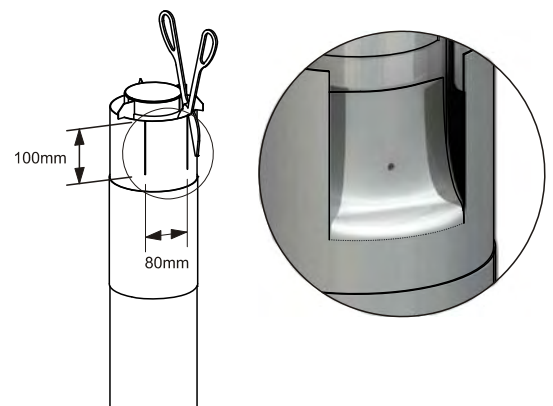

Fit cowl and drill trough the flap, flue and cowl stem. Using approximately a 1" stainless steel self tapping screw fix the cowl in place.

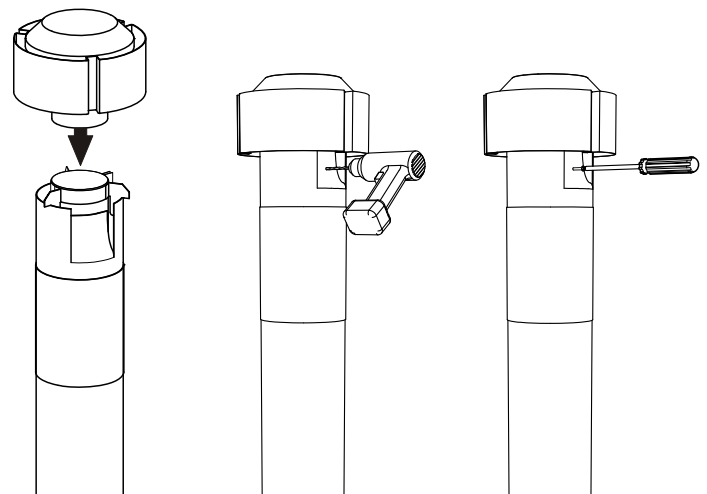

Slide the liner sleeve piece up under the cowl until it hits the flue spacer bracket. Around the bottom of the sleeve drill and rivet in three places.

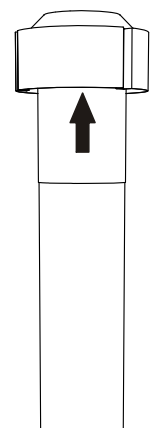

12.2 The top of the flue must be capped with an appropriate anti down draft cowl.  
 All the required flue components are available from your Escea dealer in both kitset form and as individual components.

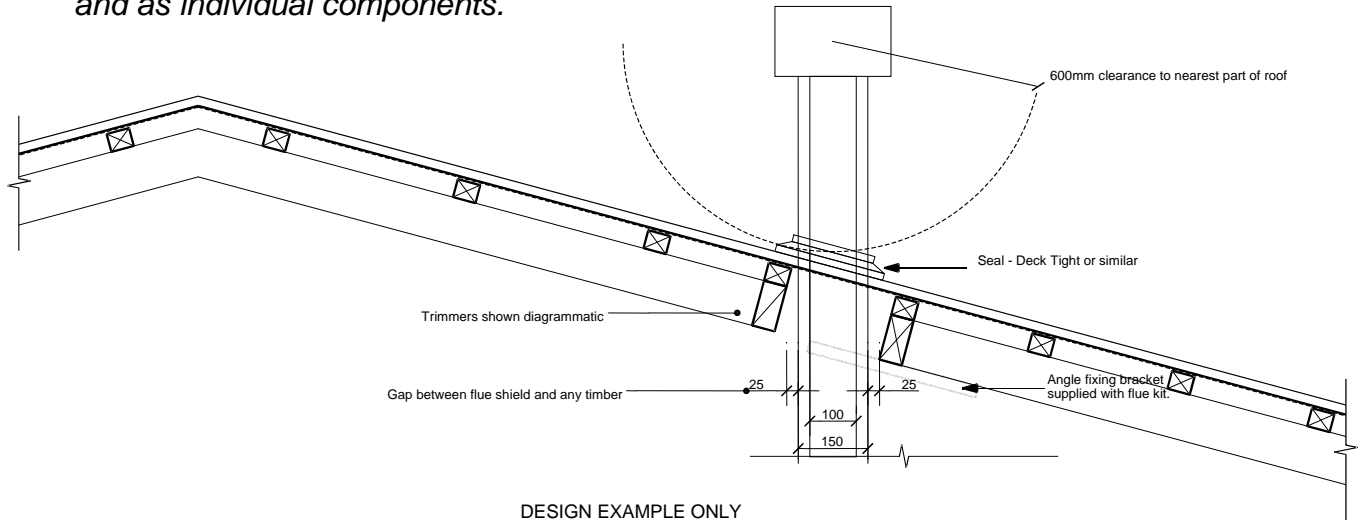

DESIGN EXAMPLE ONLY



**LONG SECTION THROUGH FLUE ENCLOSURE**

Scale: NTS

GENERAL CONSTRUCTION AND CLADDING SHOWN AND IS INDICATIVE ONLY  
 ALL INSTALLATION & FLUING MUST COMPLY WITH NZS 5261

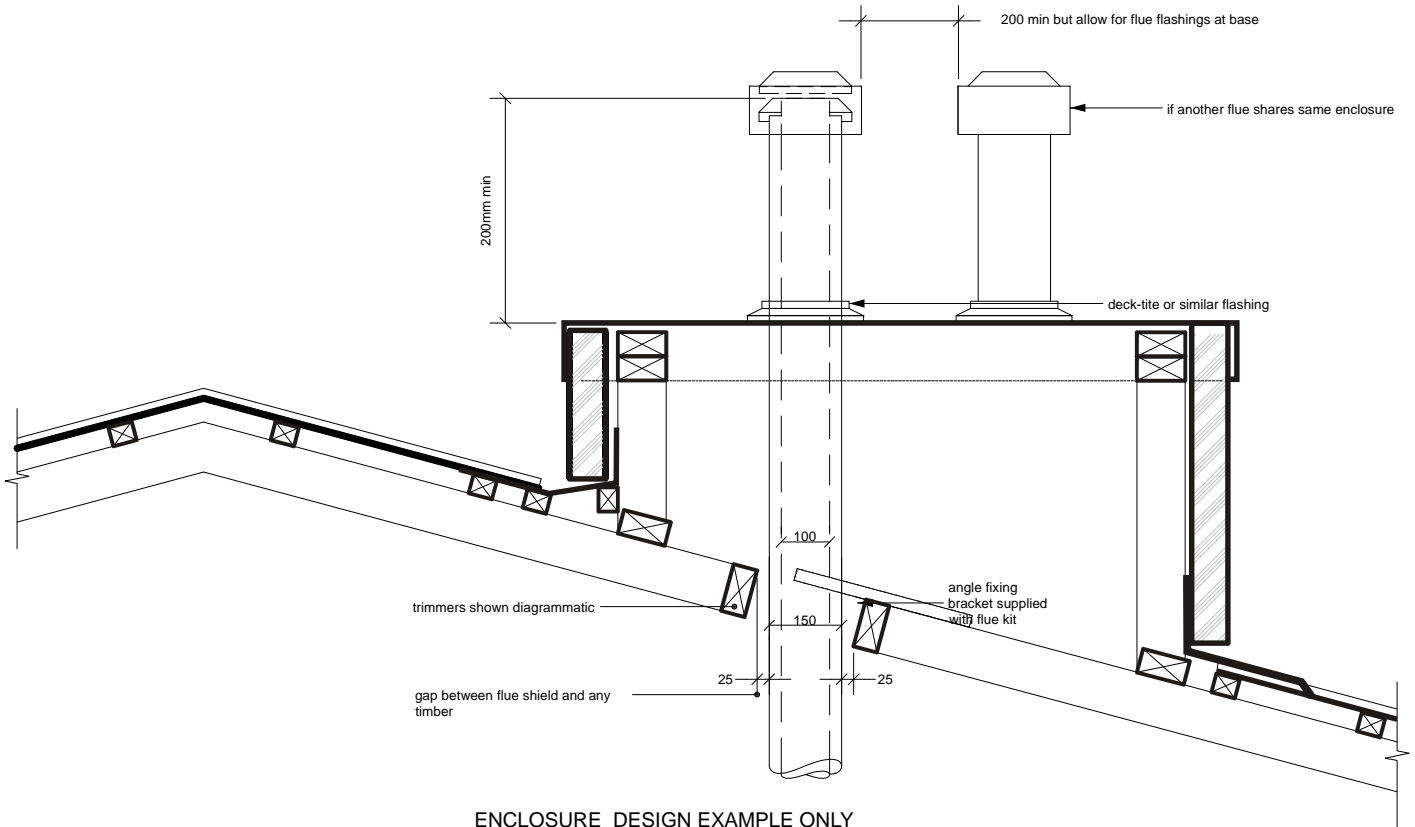

ENCLOSURE DESIGN EXAMPLE ONLY



**LONG SECTION THROUGH FLUE ENCLOSURE**

Scale: NTS

GENERAL CONSTRUCTION AND  
 CLADDING SHOWN INDICATIVE ONLY

FROM NZS 5261:2003, please ensure compliance to all other relevant sections of this code.

2.6.13 FLUE TERMINALS

2.6.13.1 Location

The termination point of a flue shall be located in relation to any associated building and to neighbouring structures so that wind from any direction is not likely to create a downdraught in the flue or chimney.

Except where 2.6.13.3 applies, a flue terminal shall:

- (a) Be at least 1m horizontally from a neighbouring structure; or
- (b) If less than 1m horizontally from a neighbouring structure, be at least 500mm above that structure;
- (c) Be at least 1.5m from any opening into a building; and
- (d) Be at least 200mm from another flue terminal.

2.6.13.2 Terminating a flue above a roof

Where a flue is to terminate above:

- (a) A roof; the end of the flue shall be at least 500mm from the nearest part of the roof;
- (b) A trafficable roof designed for personal or public use, the end of the flue shall be at least 2m above the roof level and at least 500mm above any surrounding parapet; or
- (c) A chimney, the end of the flue shall be at least 200mm from the nearest part of the chimney.

NOTE-

- (1) The distance is measured before the cowl is fitted to the end of the flue
- (2) (NA)
- (3) (NA)

2.6.13.3 Location of a flue terminal other than above a roof  
(NA)

12.3 Flue Clearance:

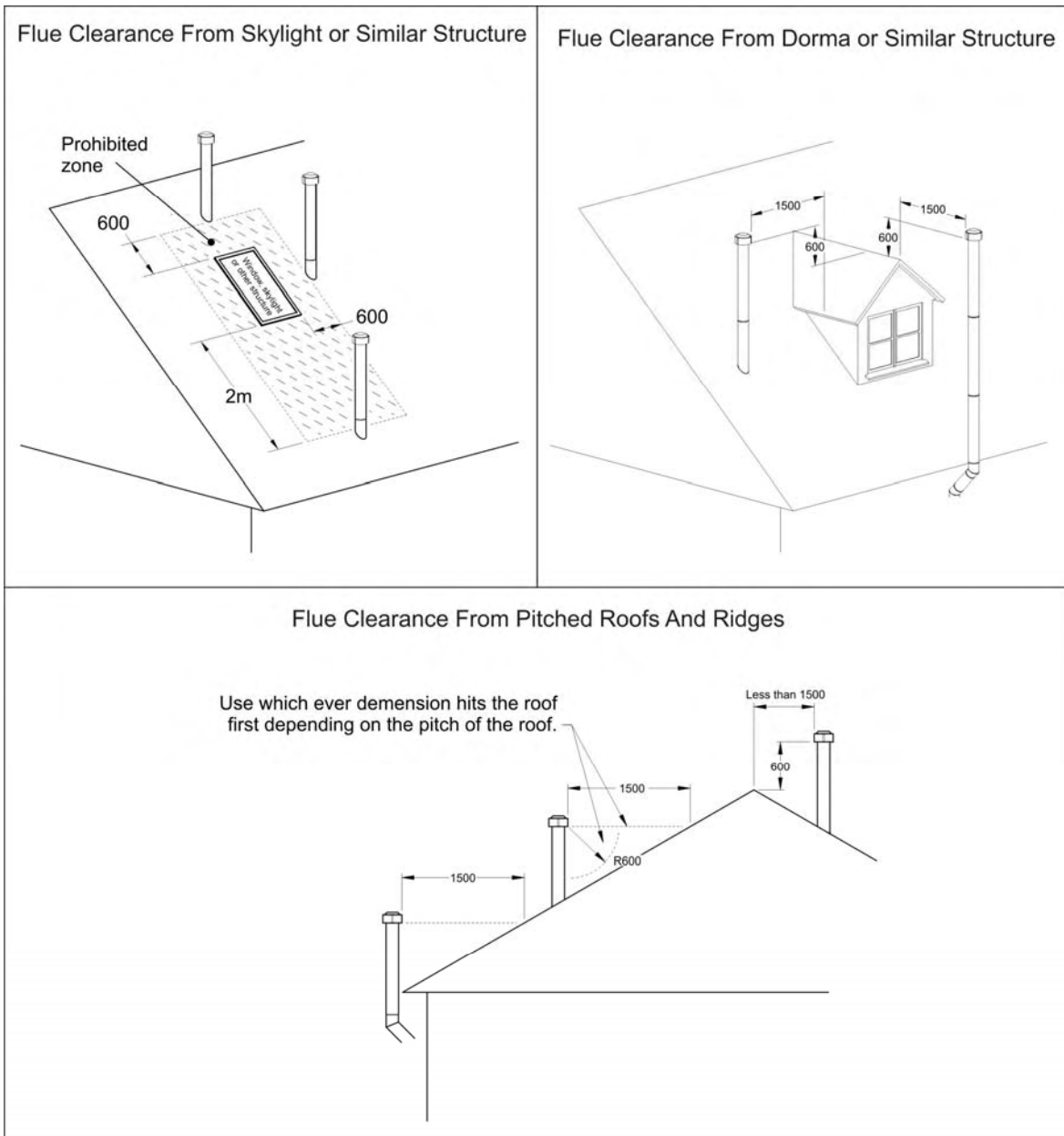

**FLAT ROOFS WITH NO PARAPET**

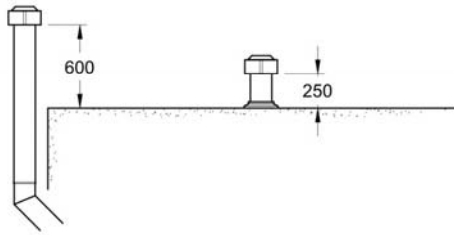

**STRUCTURE CLOSE TO FLUE TERMINAL**

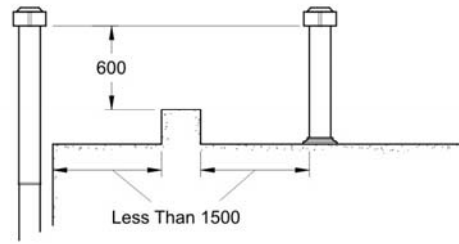

**FLUE CLOSE TO PARAPET**

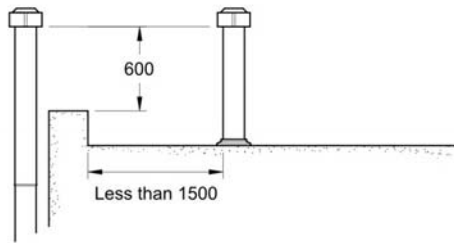

**MULTIPLE STRUCTURES (Envelope Method)**

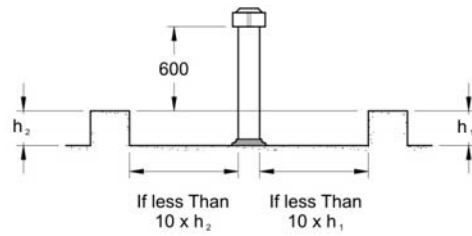

**FLUE AWAY FROM PARAPET**

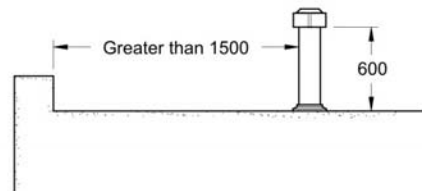

**MULTIPLE STRUCTURES AT A DISTANCE**

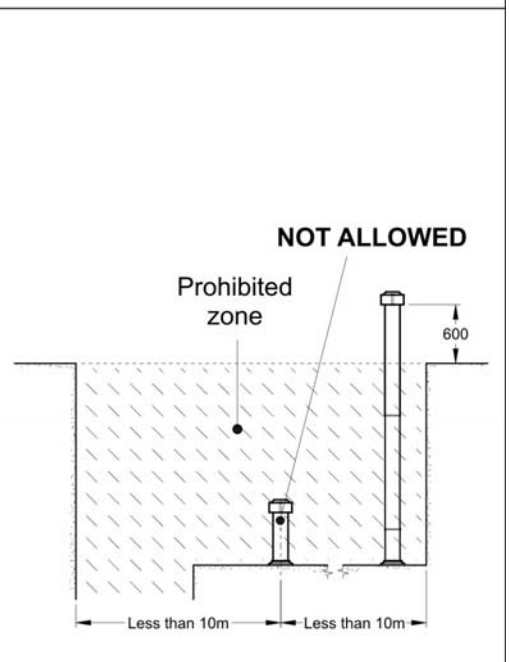
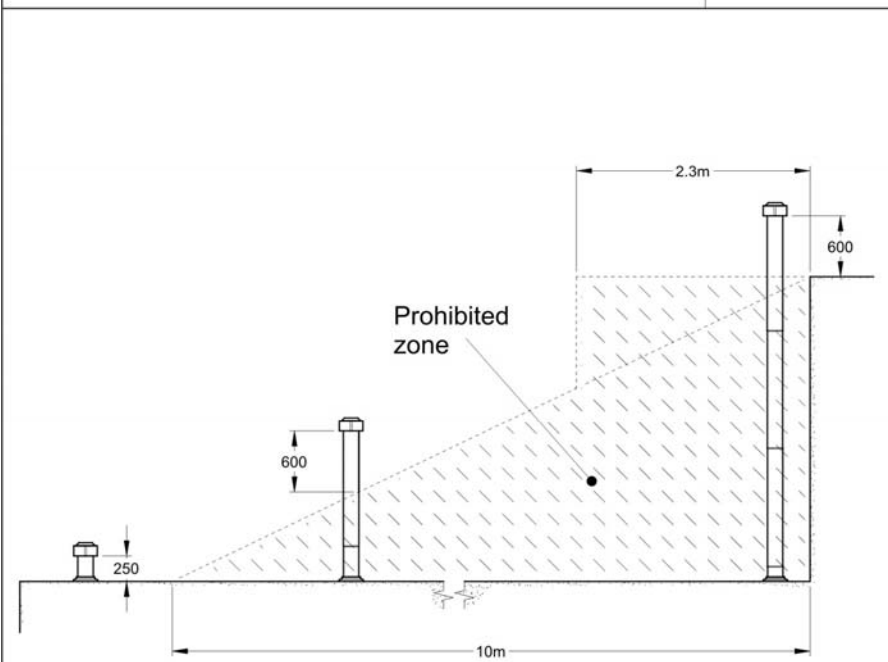
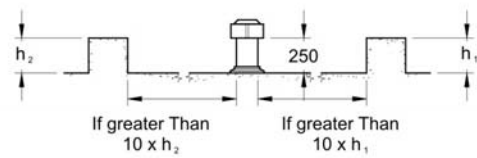

## 12.4 Fixing the Flue to the Cavity

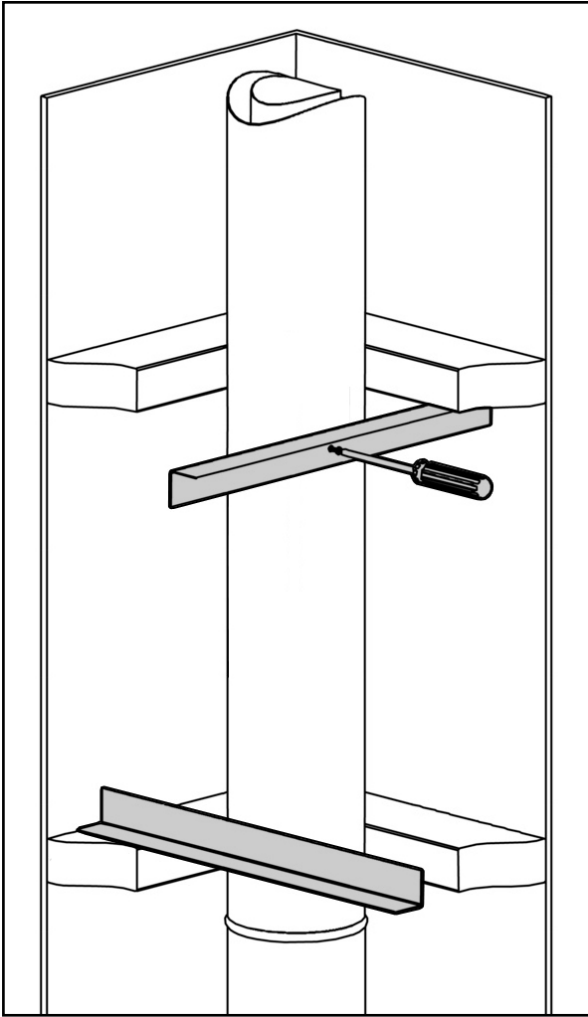

A length of Angle should be attached to the inside of the timber frame cavity to hold the flue in place. Once you have fixed the Angle to the inside of the cavity holes must be drilled to secure it to the flue. Screws or rivets can be inserted directly into the 150mm flue to hold it in place.

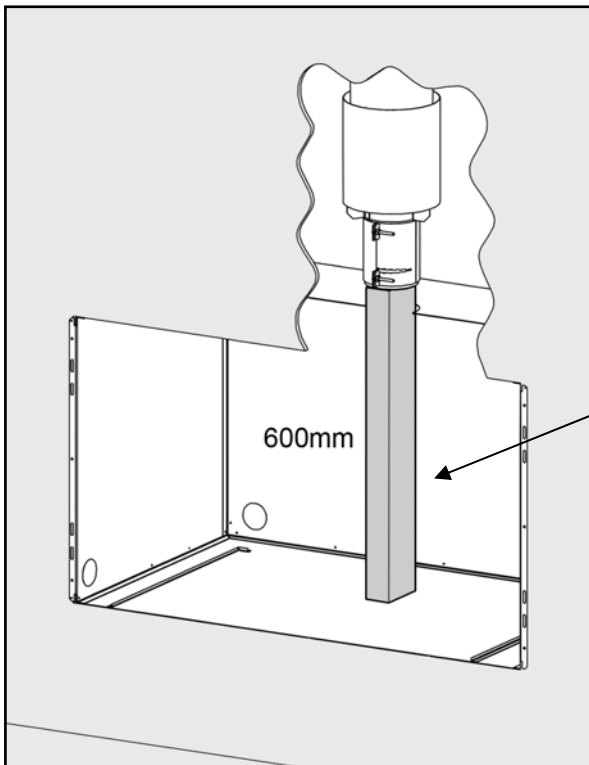

To make sure the flue is installed at the correct height, a piece of timber can be cut to 600mm and between the fire base level and the bottom of the flue. This will ensure the correct height for installation and support the flue assembly.

Timber prop. as temporary support until fireplace is installed.

### 13.0 Masonry Cavity and Chimney:

The heater can be flued with 100mm flexible aluminum ducting in accordance with NZS5261-2003. This single skinned flue must only be used where the path of the duct never comes into contact with combustible materials.

13.1 The top of the flue must be capped with an appropriate anti down draft cowl.

**Note:** Chimney liner flue kits intended for other brands of heater may not fit. Escea flue spigot is 100mm inside diameter.

### 14.0 Laying Gas Pipe:

Gas pipe should be sized as per the requirements of NZS5261-2003. The pipe sizing must be sufficient to deliver the following volume of gas to the heater with all other gas appliances in the home running at the same time;

IB1100 = 43MJ/hr

IB850 = 43MJ/hr

IB600 = 36MJ/hr

14.1 This fire has been supplied with a 300mm long flexible inlet connection to make connecting the gas supply easy and safe. Solid pipe should be run to within 100mm of the front right hand corner of the fire and connected to the end of the supplied flexible hose via a 15mm flared union (supplied with the Gas Fire).

14.2 The Zero Clearance Kit has 3 possible entry points for solid gas pipe, on the two rear corners and the front right. Each is sealed by a 'knock-out'. Remove only the knock-out which you require, and place the supplied rubber plug into the hole. You will need to make a small cut into the rubber plug to allow the gas pipe to pass through, keeping the plug as air-tight as possible.

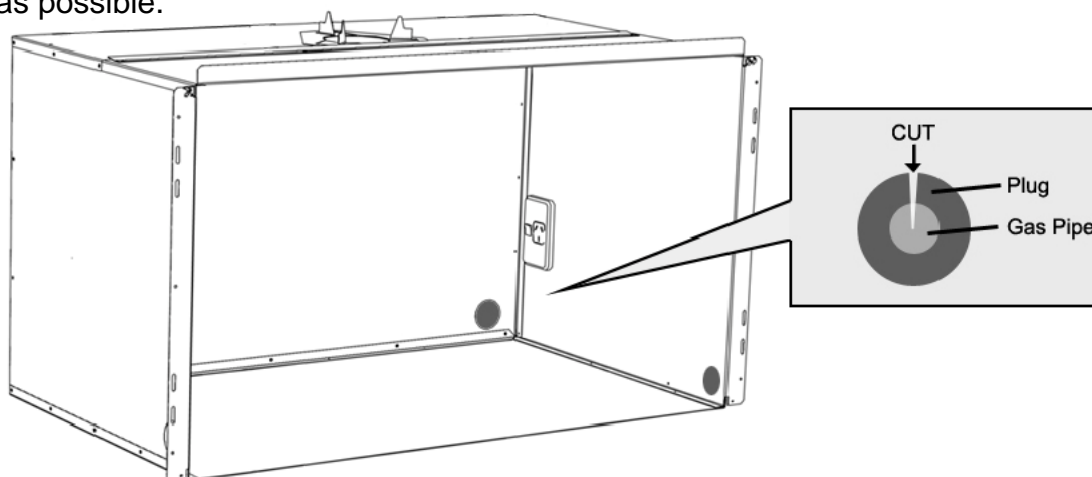

14.3 This flexible pipe should be attached to the copper supply pipe and the joint tested to ensure gas tightness. The end of the flexible connection pipe has a flare fitting and nut to suit ½ inch (12.7mm) copper pipe.

14.4 If the room has not been completed and the wall surfaces are yet to be lined or plastered the fire **must not** be installed into the Zero Clearance Kit until such time that there will be no further sanding. This will prevent dust from entering the product. Preferably the Fireplace should be commissioned after the walls have been painted.

## 15.0 Assembling the Zero Clearance Kit:

Included in the Zero Clearance Kit is:

- 1x Top-Rear panel
- 1x Top-Front panel
- 2x Side panels
- 1x Rear panel
- 1x Base panel

### 15.1 Attach the Sides to the Base:

Attach Side panels to Base, make sure Base panel flanges are on the outside, and the large flange of the Side panels faces the front.

The Right Side has a rectangular cutout, It is important that this is on the right hand Side and that the circular knock-outs are At the base of the Zero Clearance Kit as pictured.

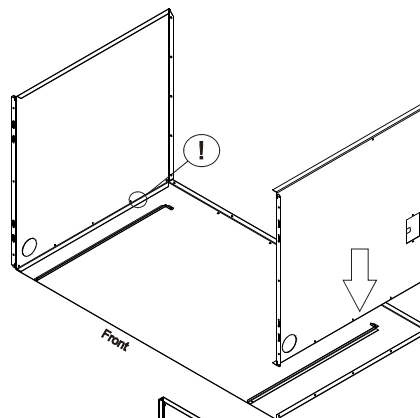

### 15.2 Attach the Rear to the Sides and Base:

The rear panel fits inside the Side and Base panels, make sure the flanges on the Side and Base panels are on the outside. The two holes on the Rear panel go towards the bottom.

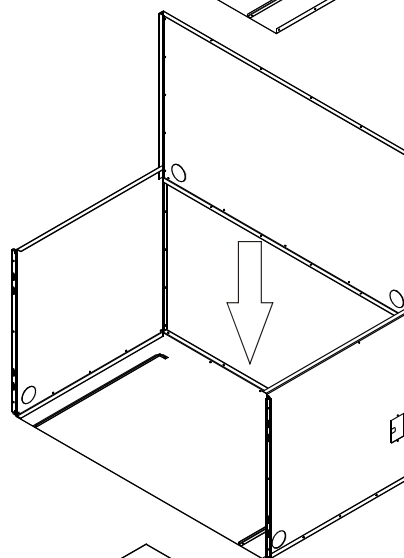

### 15.3 Attach the Top-Rear:

Attach the top-rear panel to the Sides and Rear panels, with the flanges of the Top-rear panel on the outside. Do not attach Top-Front panel yet, This will be done after the flue has been mated with the fire.

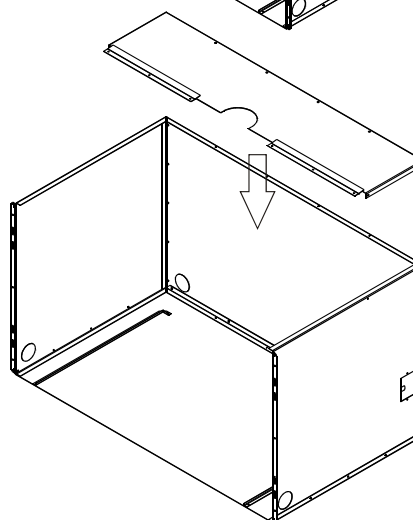

### 16.0 Fixing the Zero Clearance Kit into the cavity:

Slide the Zero Clearance Kit into the cavity, and secure it to the wall using screws or other fasteners through the slots at the front of the side panels.

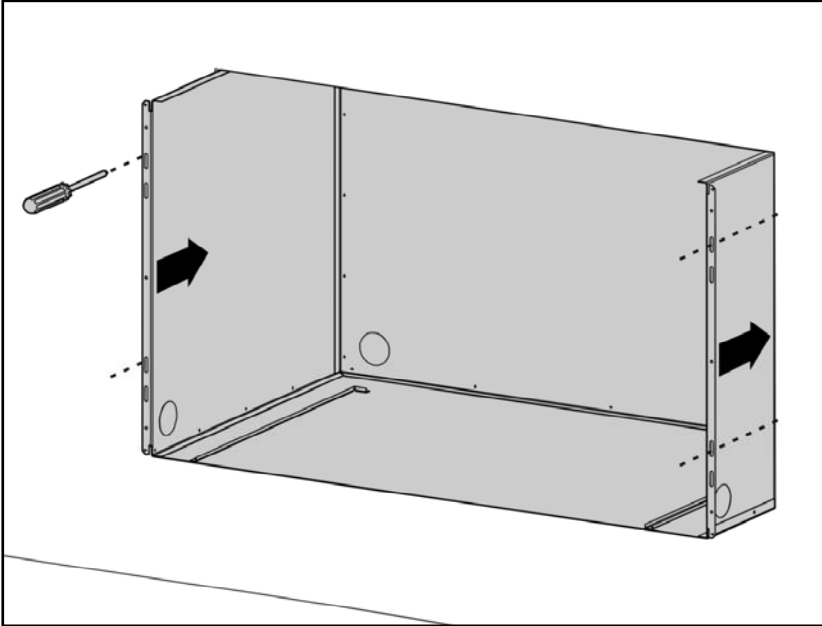

The cavity is now ready for the installation of the Gas Fireplace.

## 17.0 Gas Fireplace Installation:

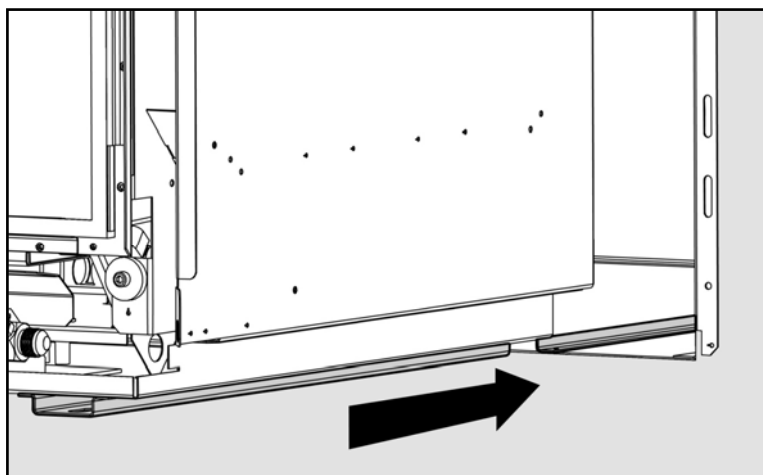

Attached to the base of the Zero Clearance Kit are guide rails. The inside edge of these rails will line up with the outside edge of the two outer under base supports. When the parts are lined up, push the fire towards the back of the Zero Clearance Kit until it cannot be pushed back any further. The front of the firebox should now be sitting flush with the ZCK.

## 17.1 Removing the Front Glass:

**Step 1:** Unscrew the side (where fitted) and top glass retainers and remove them. Take care that the glass does not fall forwards at this stage

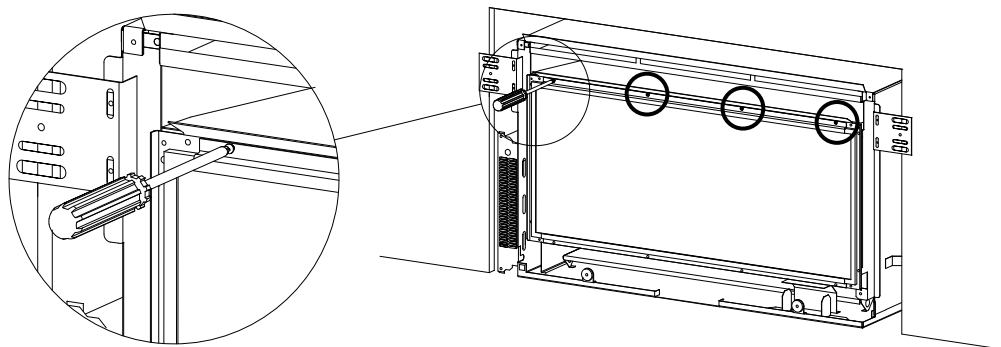

**Step 2:** Lift out glass and place it carefully aside.

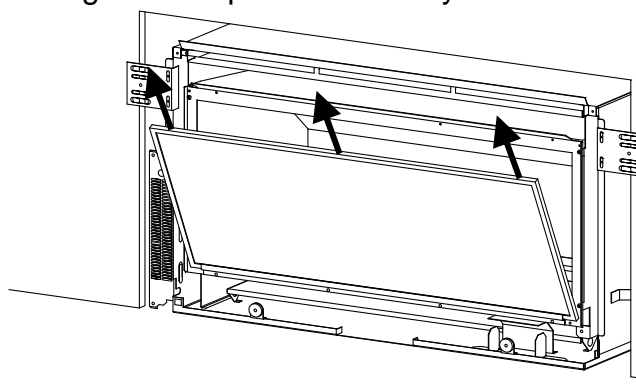

**Step 3:** For best access we recommend removing the fire box. Undo the four screws on the front four corners of the fire box and the two screws on the inside holding down the fire box (as shown below). Pull the fire box out of the heater.

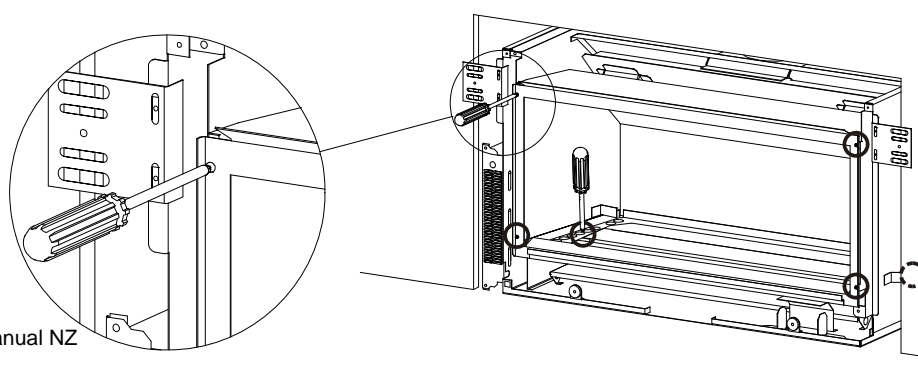

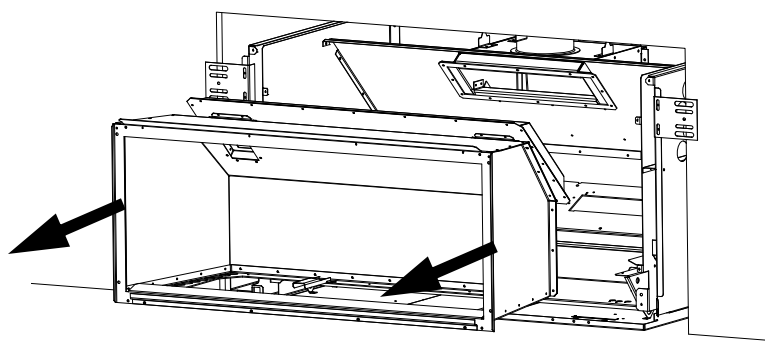

## 18.0 Attaching the Flue to the Fireplace:

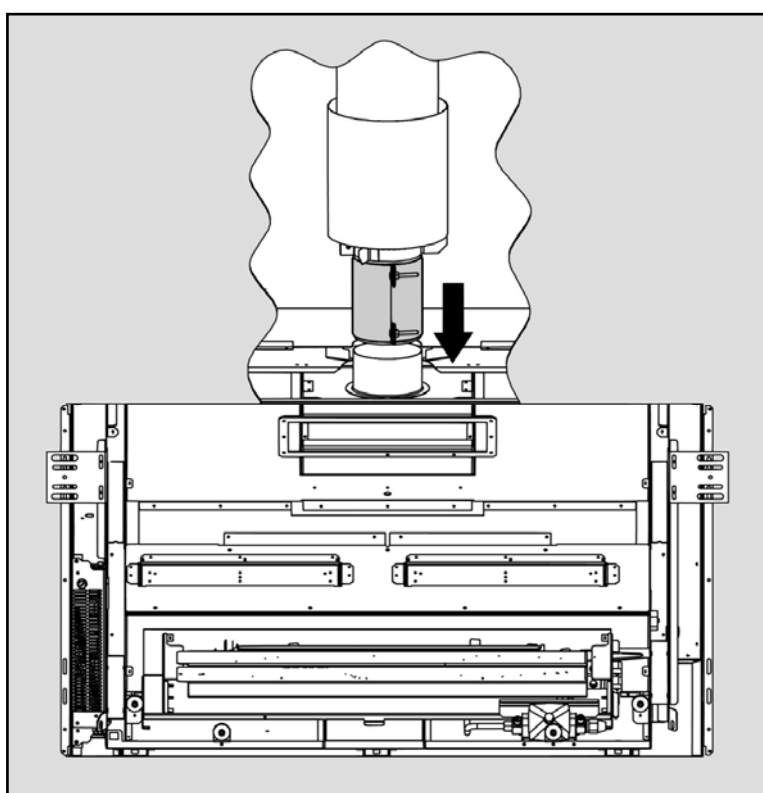

Once the gas fireplace has been inserted into the ZCK and the firebox removed, the flue can be attached. To do this line up the 100mm flue with the flue outlet spigot then slide the clamping flue sleeve down onto the spigot.

Note: To increase access through the fire to reach the flue connection, remove firebox and lid.

**Please consider how the fire will be fixed to the base before installing. Refer to 20.0 for details**

## 19.0 Connecting the Gas Pipe:

When the heater has been pushed back into position the 300mm flexible braided stainless steel gas pipe (supplied) can be connected to the inlet side of the appliance regulator at the front RH corner of the heater. The hose and pipe assembly should have already been tested as per section 12.2.

19.1 If the installer chooses not to use the supplied flexible inlet pipe then 12mm copper can be run directly to heater and connected onto the regulator with flare nut (BSP thread). The regulator that is supplied with the fire **MUST NOT BE REMOVED**. Removal of the regulator, or replacing it with one not intended for use with an Escea fire, will void the limited appliance warranty.

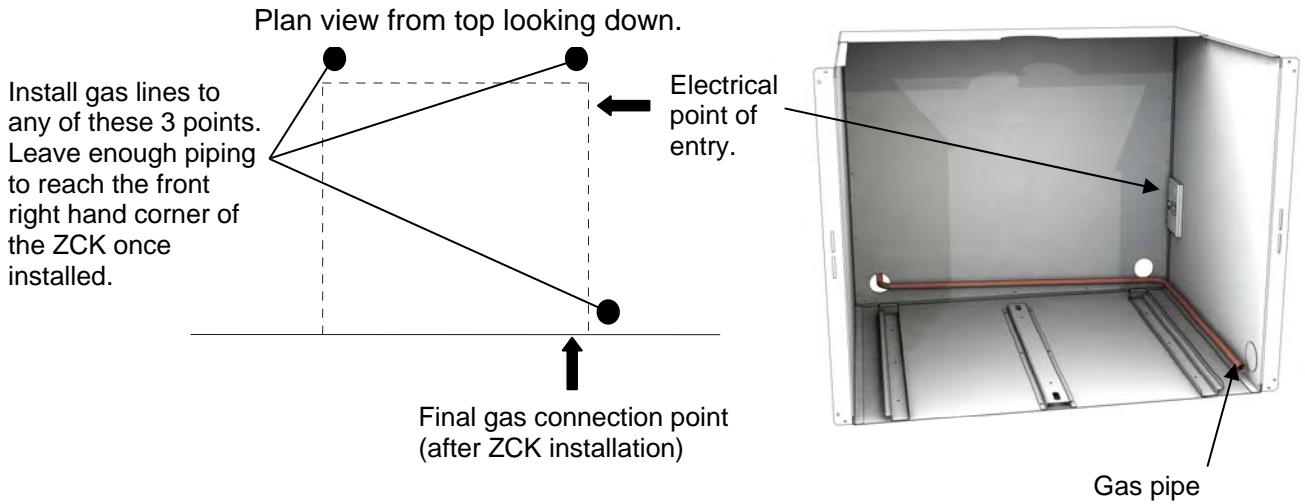

**20.0 Fixing the Heater to the Base and Wall:**

There are several ways that the heater can be fixed against movement: **It is a requirement that this heater be securely fastened to the wall and base.**

*Note: It is important that the outer fascia is used during this process to ensure that the heater is located in the appropriate position within the cavity.*

**20.1 Fixing Heater to Base:**

The heater has several holes along the front edge of the base panel that have been provided to allow installers to screw the heater to the floor. Because of a lack of access for drilling it may be necessary to mark the appropriate location for these screws and then remove the heater and drill holes into hard flooring.

Alternatively a socket set can be used to drive in hex headed screws.

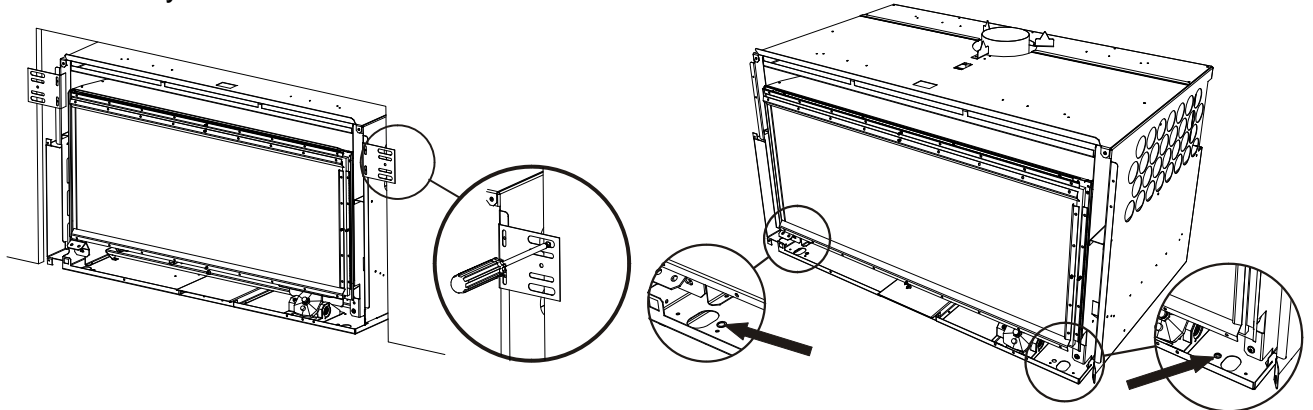

**20.2 Fixing Heater to Wall:**

The installer must also fix the heater to the sides of the cavity using the bracket kit provided. These brackets must be installed over the outer lining surface of the wall i.e. over the Plaster Board rather than onto a stud which is then subsequently covered with a wall lining. Otherwise the fire will be sitting too far back and will inhibit the outer fascia panel from fitting correctly.

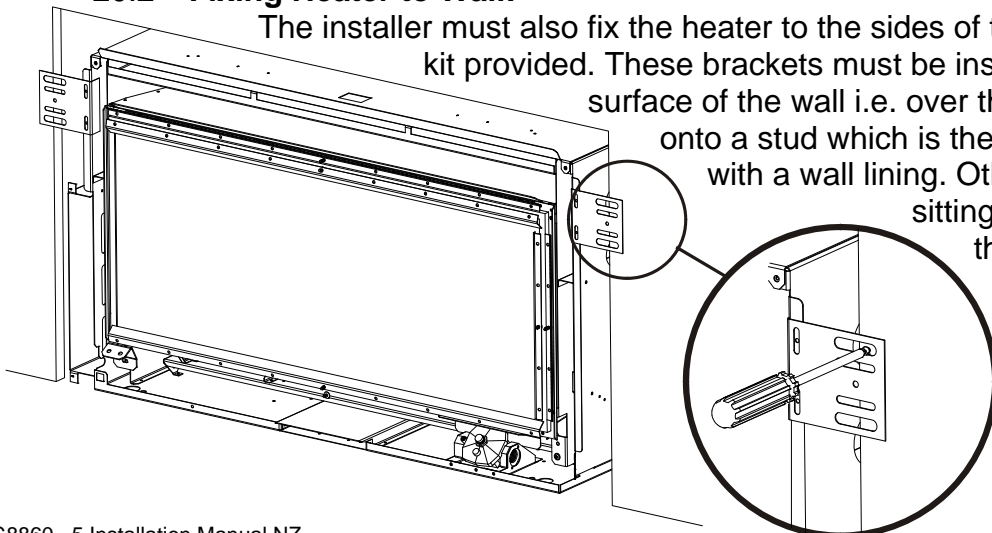

### 21.0 IB850 & IB600- Locating the Log Set After Replacing the Fire Box:

- 1) Remove packaging from around log sets
- 2) Place rear log (long rectangular one) into position by inserting it in behind retainer brackets at rear of fire box.
- 3) Place the front log sets into position over the top of the main burners. Use the log template to properly locate the logs. The front edge of each log should have its front edge directly behind the holes in the top of each burner which should follow the contours of the logs.

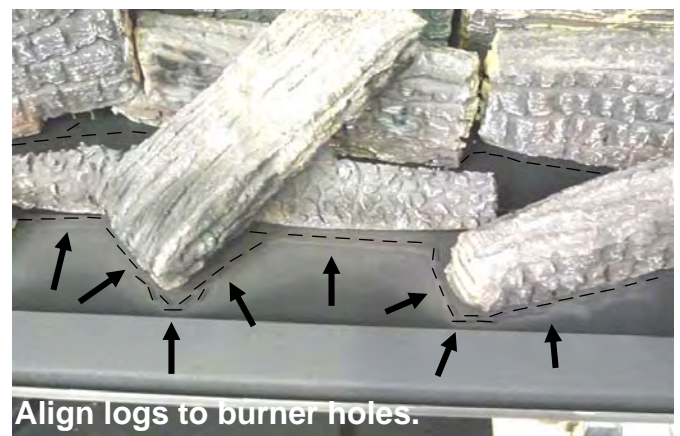
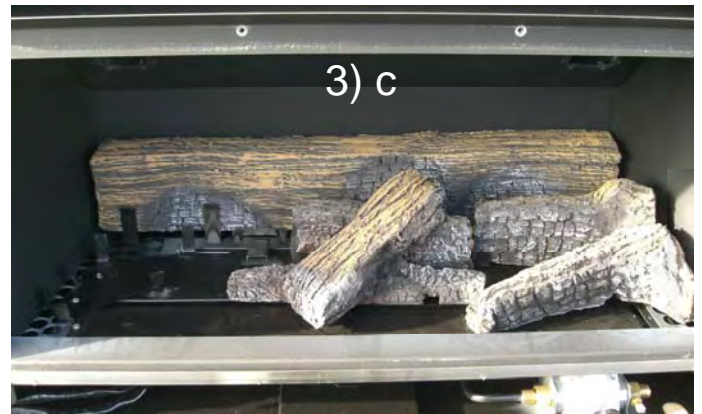
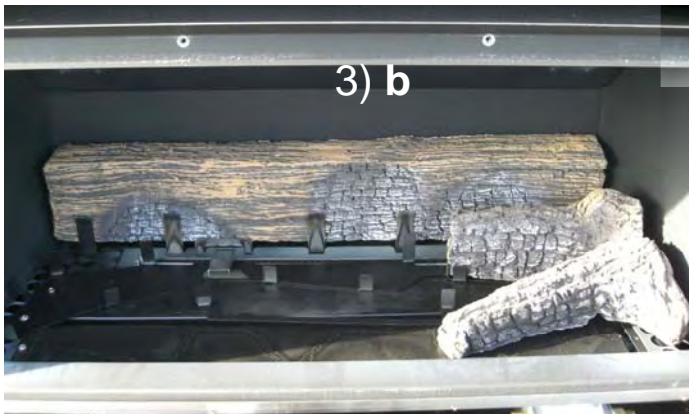
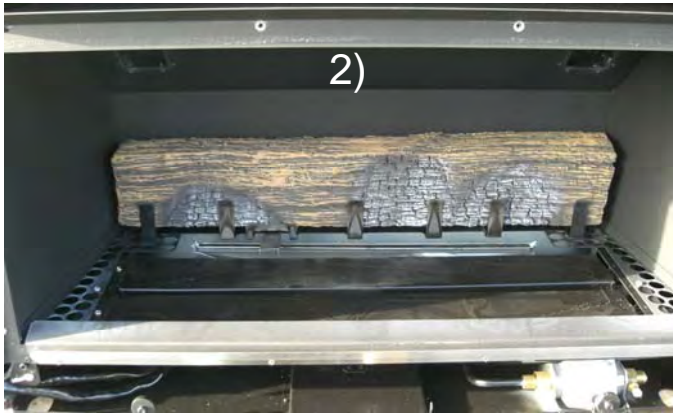

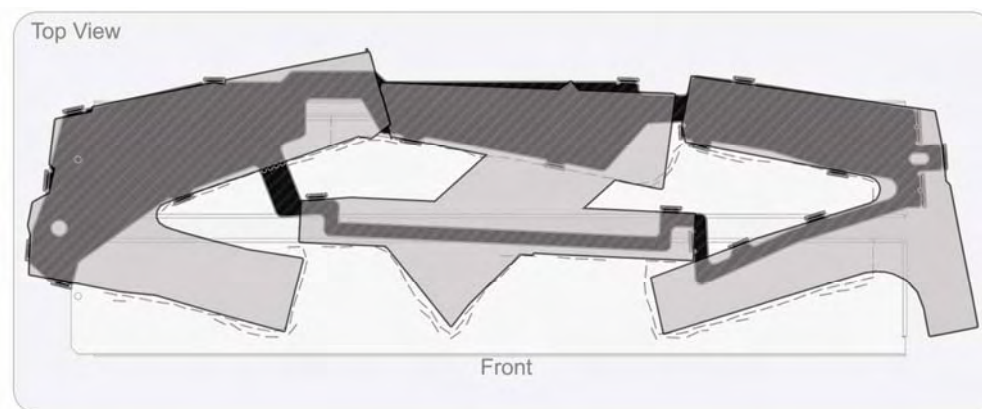

IB850 Log & Template Position



- 4) Line up some of the coals that have been supplied with this appliance, along the burner holes in front of the logs.



- 5) Scatter the remaining coals around to fill the empty spaces left over.

### 21.1 IB1100- Locating the Log Set After Replacing the Fire Box:

- 1) Remove packaging from around log sets
- 2) Place 2 x rear logs (long rectangular ones) into position by inserting in behind retainer brackets at rear of fire box.
- 3) Place front three log sets into position over the top of the main burners. Use the log template to properly locate the logs. The front edge of each log should be located so that its front edge is directly behind the holes in the top of each burner which should follow the contours of the logs.

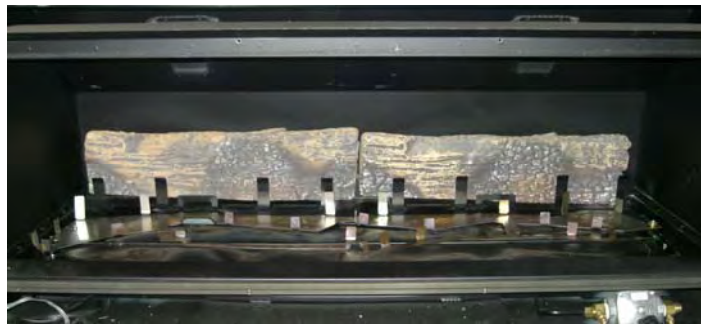

- 4) Cover empty spaces around logs with small coals as per 4) & 5) on previous page

### 21.2 Log Replacement:

The fire unit should never be used with broken logs. Turn off the fire and allow the unit to cool before removing the glass to carefully remove the logs. If for any reason a log should need replacement, you must use the proper replacement log. The position of these logs must be as shown in the diagrams above.

**Note: Improper positioning of logs may create carbon build-up and will alter the unit's performance. Malfunctioning due to improper log placement is not covered under warranty.**

### 22.0 Electrode placement:

The placement of the electrodes is CRITICAL to the operation of the fire. These are factory set but if the event that they are moved during installation or the fire is having trouble lighting or staying lit then below is a guide to electrode placement. Ensure no logs or coals are touching the electrodes.

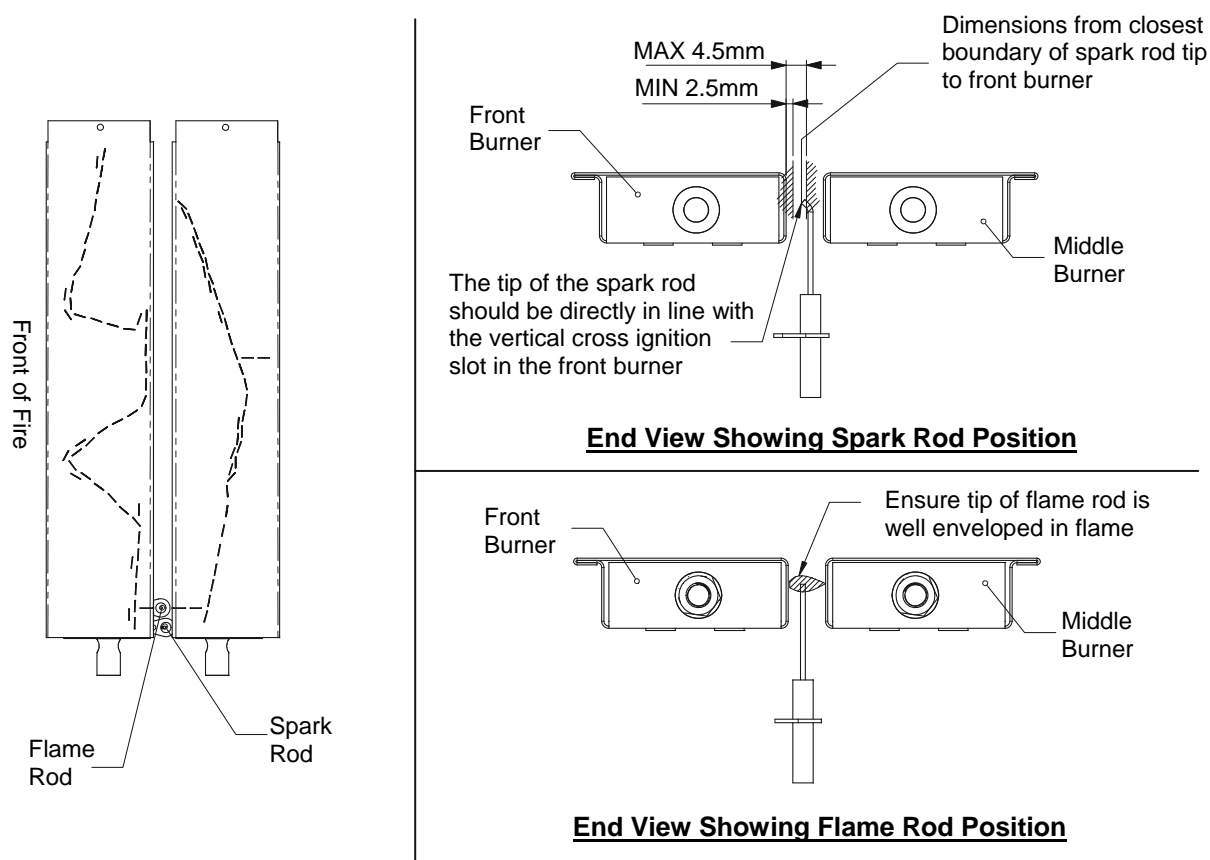

### 23.0 Checking Operating Pressure:

**WARNING:** The regulator that is supplied with the fire **MUST NOT BE REMOVED**. Removal of the regulator, or replacing it with one not intended for use with an Escea fire, will void the limited appliance warranty.

This is done at the regulator located at the front RH corner of the appliance. This is best done before the fascia panels have been fitted to avoid fascia damage. Pressure test points are available for both inlet and operating test pressure (as shown below).

- 1) Remove inlet pressure test point screw and attach manometer tube.
- 2) Run the heater on full (all burners running) and measure inlet pressure with all the other gas appliances running. If pressure does not fall within the maximum or minimum

pressures listed on the table below then reassess installation pipe size or upstream regulator settings. Replace inlet test point screw.

- 3) Remove the operating pressure test point screw. Connect manometer tube and measure pressure with heater running on full (all burners running) and with all the other gas appliances running.
- 4) The heater regulator pressure has been factory set to 1.0Kpa for Natural Gas heaters and 2.30Kpa for LPG heaters. Please check that the operating pressure is exactly as listed and if not, adjust screw in centre of regulator until pressure is correct.
- 5) Replace operating test point screw and leak test both test points.

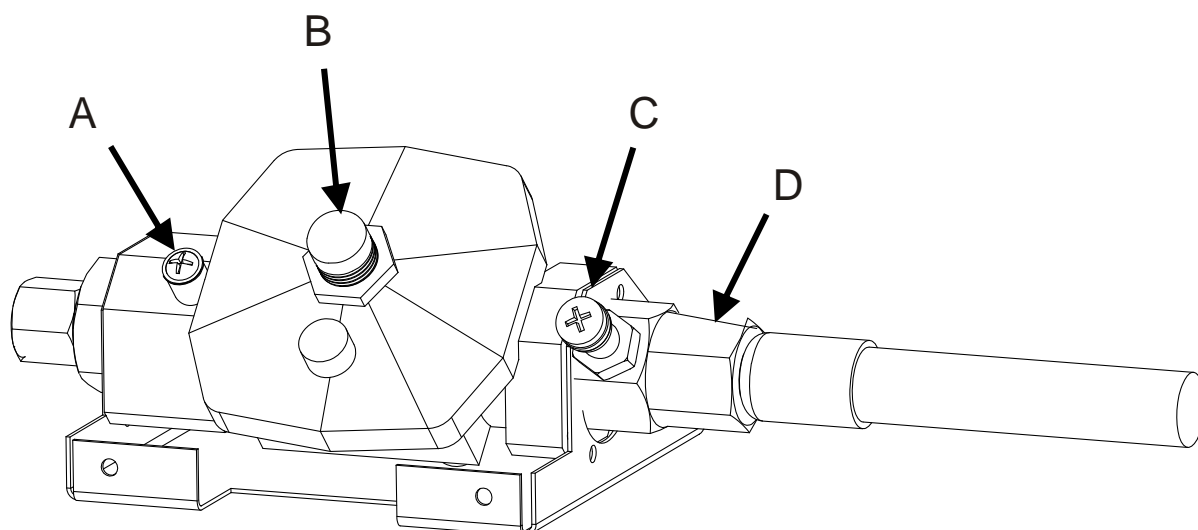

**A** = Operating pressure test point

**B** = Pressure adjustment screw

**C** = Inlet pressure test point

**D** = Inlet gas connection.

IB Series Pressure Table	Gas Type	
	LPG	Natural
Minimum Inlet Pressure	2.5kPa	1.2kPa
Maximum Inlet Pressure	5.0kPa	5.0kPa
Operating Pressure	2.30kPa	1.0kPa

## 24.0 Fitting the Fascia Panels:

To avoid scratches or knocks to the fascia panels of this heater they must be fitted at the complete conclusion of the installation process. It may be necessary to use the outer fascia to initially locate the heater but then remove it again so that there is no chance of damage.

**Note:** Never Ever Rub the Fascia Panels.

**Step 1:** Replace the glass  
**Note:** If the glass gasket requires a replacement, call your nearest Escea agent who will ensure the part is replaced with the correct type. In the event that the glass is broken by impact, purchase the replacement from an authorised Escea agent only.

**Step 2:** Hang the outer fascia (larger one) from the lip that extends at the top of the heater at 45 degrees. If hanging a 4 sided fascia please Refer to sections 25.1 and 25.2 on the next page.

**Step 3:** Fit the two screws at the base of each side of this fascia. The heater may have to be adjusted in or out of the cavity to ensure the fascia fits correctly.

**Step 4:** Hang the top edge of the inner fascia (smaller one) from the lip that extends at 45 degrees from the top of the firebox. This fascia is held in at its base by magnets (IB850 & IB600). Alternatively, this fascia is screwed to the fire chassis (IB1100).

**Step 5:** Place the bottom fascia trim into position. This panel is held on with magnets. If this panel does not fit, adjust the outer fascia side to side or the heater in/out until the trim fits well.

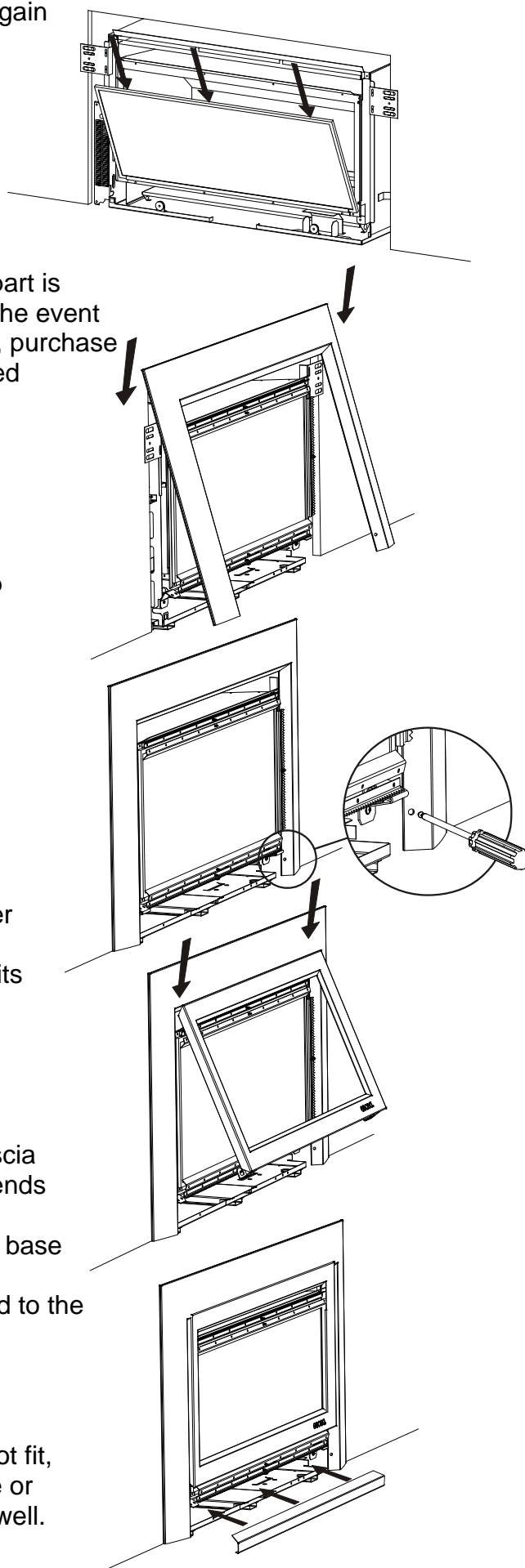

- 24.1 When installing a 4 sided fascia ensure that the clips that the outer fascia screw into are at the bottom of the slot on which they are attached as shown below. The outer fascia should be pushed down onto the top lip so that it is as low as possible and the screw holes in the fascia line up with the lowered clips.

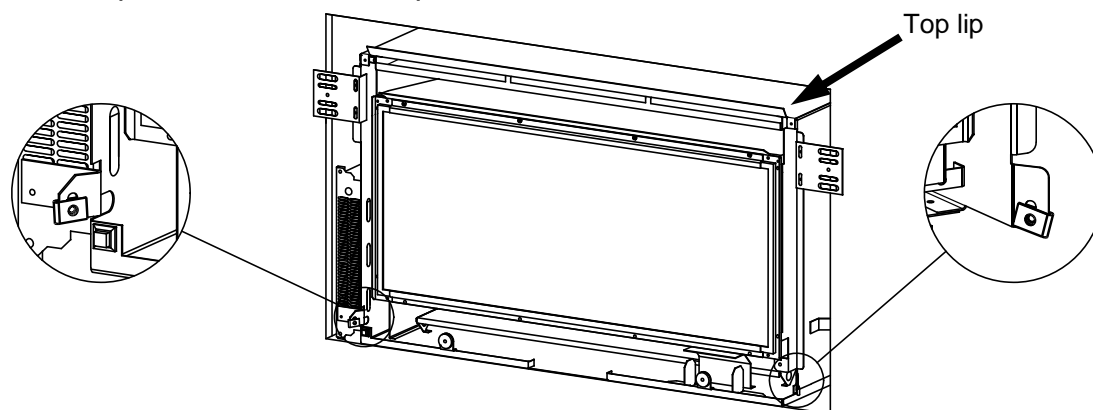

- 24.2 This is especially important for the IB600 as a good gap between the bottom of the 4 sided outer fascia and the removable bottom fascia strip is vital for ventilating the electronics tray. If this is not done the fire can produce an “E1” electronic over temperature error.

### 25.0 Locating Wall Mount Cradle for Wireless Control;

The heaters remote contains the thermostat that will sense the room temperature and communicate this back to the heater via radio frequency.

A wall mount cradle has been provided for the wireless control and where possible the control should be housed in this cradle.

The location of this cradle should be decided by taking into account the following factors;

1. Simple, convenient access for the user
2. Away from air flow and drafts through the room
3. The parts of the room that people are likely to spend time
4. Away from direct sun light
5. A suitable distance away from the heater.
6. Ideally 1.2m to 1.5m from the floor

The radio frequency signal will go through some walls but for best results escea suggest that the cradle position is between 5 and 15 metres away from the heater.

The best height off the ground to locate the cradle is about chest height. This gives a good average room temperature and easy access for the user.

Please ensure that cradle is screwed firmly onto the wall using the screws provided.



## 26.0 Normal Operating Sounds and Smells;

**Note:** Each time the fire is lit from cold the glass may fog up with condensation. This is normal and the condensation will disappear within a few minutes once the glass heats up.

### 26.1 Sounds

It is possible that you will hear some sounds from your gas appliance. This is perfectly normal due to the fact that there various types of materials used within your appliance. Listed below are some examples. These are all **normal operating sounds** and should not be considered as defects in your appliance.

#### **Fan:**

Escea gas appliances use electric fans to push heated air further into the room. It is not unusual for the fan to make a “whirring” sound when ON. This sound will increase or decrease in volume depending on the speed setting of your fan.

#### **Gas Control Valve:**

As the gas control valves turn ON and OFF, a dull clicking sound may be audible, this is the normal operation of a valve. When the fire is switched off after being run for a while, there may be popping and fluttering noises as the residual gas in the burners burns away. These are normal and should be no cause for concern.

#### **Unit Body/Firebox:**

Different types and thicknesses of steel will expand and contract at different rates resulting in some “cracking” and “ticking” sounds being heard throughout the heating and cool down processes.

### 26.2 Smells:

The first few times the unit is operated, the unit may release an odour and the flames will appear orange caused by the curing of the paint, the burning off of the starch in the gas logs and the oils in the metal. This is a temporary curing process which will disappear with use.

A deposit on the inside of the glass, caused by the starch in the logs, may appear as a build up after several uses. If this film is not removed, it will bake on and may become difficult to remove. When the glass is cold, remove it (see page 14) and clean the inside with a non-abrasive cleaner.

**DO NOT ATTEMPT TO CLEAN THE GLASS WHILE IT IS HOT. NEVER OPERATE THE UNIT WITH THE GLASS REMOVED.**

## 27.0 Installation Check List:

Tick here

- 1 Ensure there is adequate ventilation in the cavity. \_\_\_\_\_
- 2 Ensure the spark electrodes are correctly positioned. \_\_\_\_\_
- 3 Operating pressure checked with heater running on full (all burners operating) and all other gas appliances in the house switched on. \_\_\_\_\_
- 4 Flue Draw checked, 5 minutes after start up. \_\_\_\_\_
- 5 Logs in correct position. \_\_\_\_\_
- 6 Coals spread along front burner. \_\_\_\_\_
- 7 Heater run on high for 60 minutes with house doors and windows open to clear smell of paint and oils initial burn. \_\_\_\_\_
- 8 Hearth and mantle clearances comply with these instructions
- 9 No combustible materials any closer to heater than these instructions allow. \_\_\_\_\_
- 10 Heater fixed to wall and floor. \_\_\_\_\_
- 11 Leak test all joints and pressure test points. Soapy water drop test done on pipe work. \_\_\_\_\_
- 12 Wall mount cradle screwed to wall. \_\_\_\_\_
- 13 House holder has been shown how to operate heater. \_\_\_\_\_
- 14 Operator manual has been left out for house holder, installer has filled in their own details and heater serial number into warranty card. \_\_\_\_\_
- 15 Ensure adequate access to power flue units. \_\_\_\_\_
- 16 If using a Power flue unit, make sure the electrical tray is wired up correctly. \_\_\_\_\_
- 17 Inform the customer that the fire may continue smelling for a while after installation depending on frequency & duration of use \_\_\_\_\_
- 18 Given House Holder Plumbing Industry Commission Compliance Certificate. \_\_\_\_\_