

Any enquiries contact the dealer from whom you purchased your heater.

PLEASE COMPLETE:

Dealer name: _____

Dealer Address: _____

_____ Phone Number: _____

Please attach your original purchase dockets to this instruction book for future reference.

WARNING For installation through masonry walls only.
Read and follow these instructions (in conjunction with the manual) carefully before installing this appliance.
SAVE THESE INSTRUCTIONS

- The installation of this appliance must be carried out as per this manual and the flue manufacturer's specifications. We recommend that you use a qualified installer to carry out the installation.
- If you have any other enquiries, please contact the dealer from whom you purchased your heater.
- This appliance weighs in excess of 218 kilograms. Extreme care should be taken when handling the appliance.

Hole construction dimensions

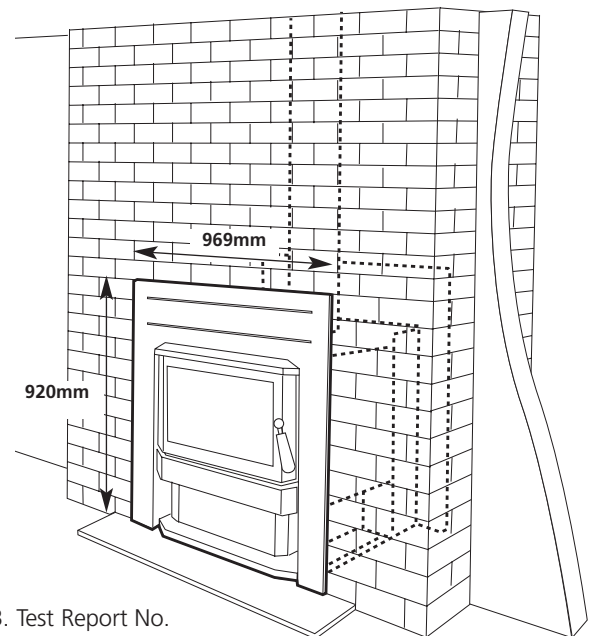
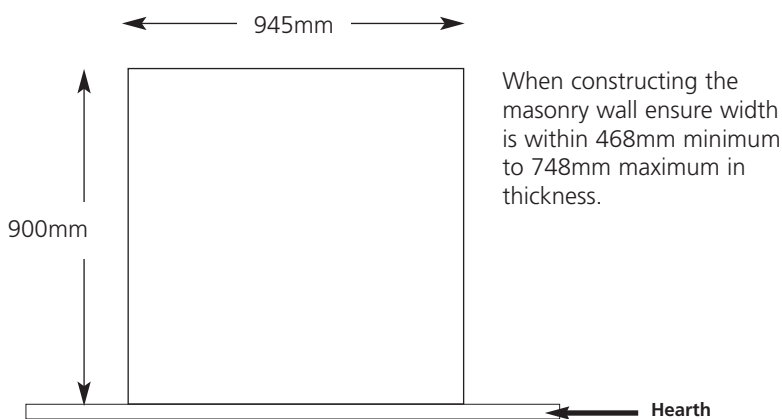

Clearances to combustibles

This heater has been tested to the Australian Standard 2918:2001 Appendix B. Test Report No. HCMG/05/002. For this installation the flue kit could vary and should be installed to AS/NZS 2918:2001.

This heater conforms to the Australian Standard in the following placement of the appliance in relation to combustible surfaces:

A minimum 969mm wide x 1800mm deep x 6mm thick floor protector should be used under and in front of the appliance when installing. The floor protector should extend 500mm in front of the appliance base on both doors.

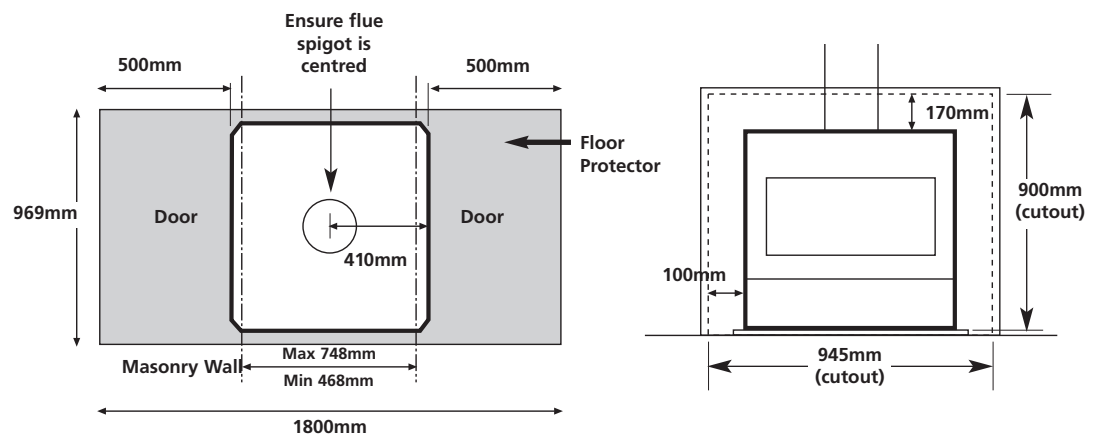

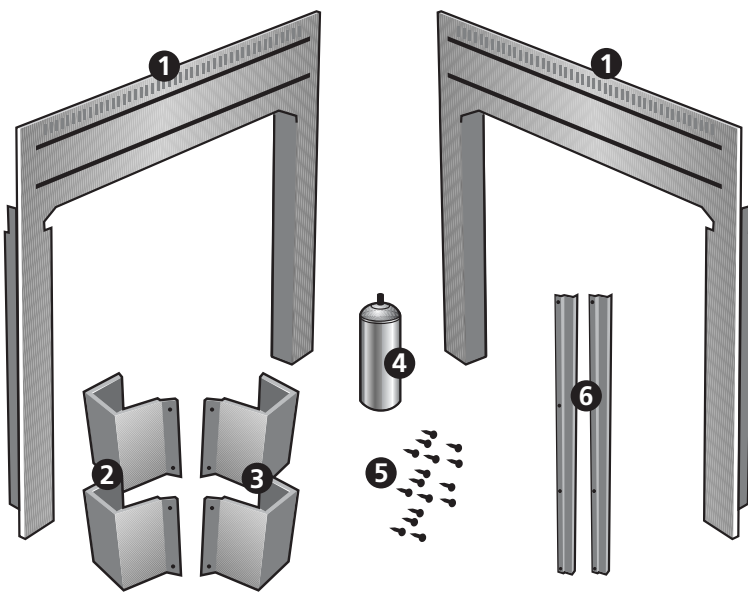

Parts

1. Fascia Assembly - qty 2 (includes 3 bolt on panels on back)
2. Panel fascia - lower left hand - qty 2
3. Panel fascia - lower right hand - qty 2
4. Spray can
5. 8G self tapping screws - qty 18
6. Fascia retaining strips - qty 2
7. 3mm dia. drill (Not shown)
8. 5mm dia. drill (Not shown)

Heater to be assembled from steps 1 to 4 before placing into masonry fireplace.

Step 1

1. Remove screws from the heater pedestal fascia panels
2. Position lower fascia panels (Parts 2 & 3) as shown (one on each side and end of heater)
3. Reattach screws for both pedestal fascia panels.

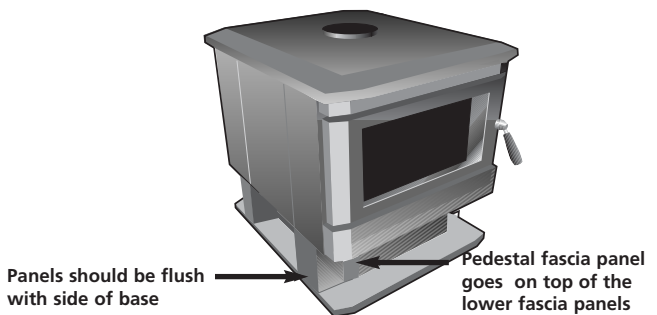
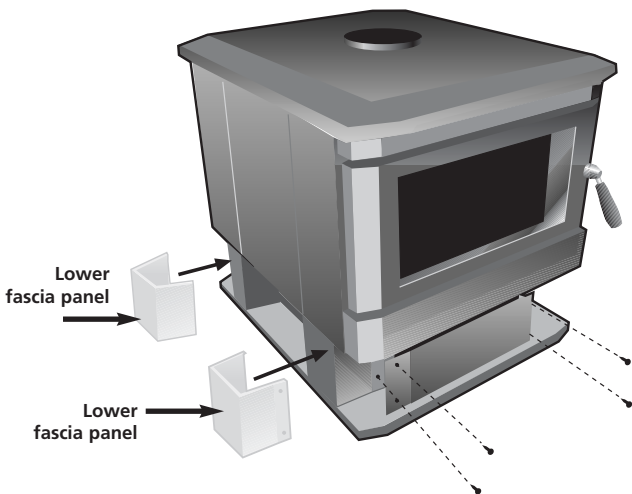

Step 2

1. Loosen (do not remove) 5 nuts on rear of fascia assembly (Part 1) so that the three bolt-on panels are free to move.
2. Slide one fascia assembly (Part 1) over the front of the heater, so that pre-drilled screw holes (A) and (B) are aligned. (NOTE: These holes allow for a 748mm wall thickness.)
3. Insert screw (supplied) and tighten.
4. Do this on each side of the heater.

NOTE: If the wall thickness is between 748mm and 468mm, you will need to drill a new 3mm dia. hole (A). Position it so that the flue spigot will be centred within the wall cavity. e.g if the wall thickness is 700mm, the hole should be drilled 272mm from the centre of the spigot

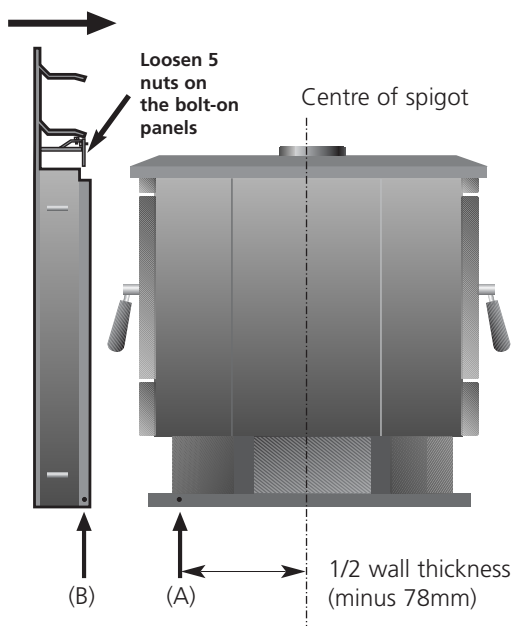

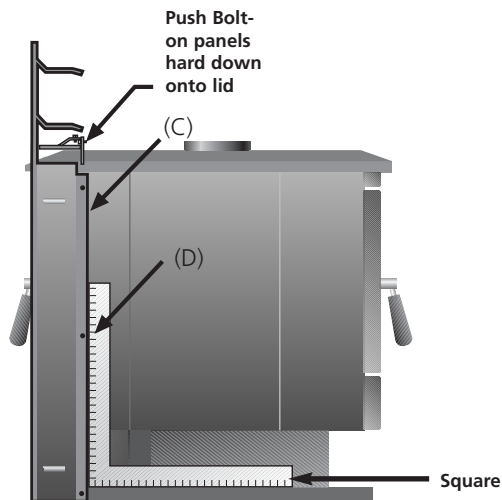

Step 3

1. Use a square to ensure the fascia assembly is perfectly vertical.
2. Using a 3mm dia drill bit (supplied), drill holes (C) and (D) through the fascia assembly and into the side of the heater. Insert screws (Part 5) and tighten. Do this on the other side of the heater as well.
3. Whilst holding the bolt-on panels hard onto the heater lid, tighten the 5 nuts.

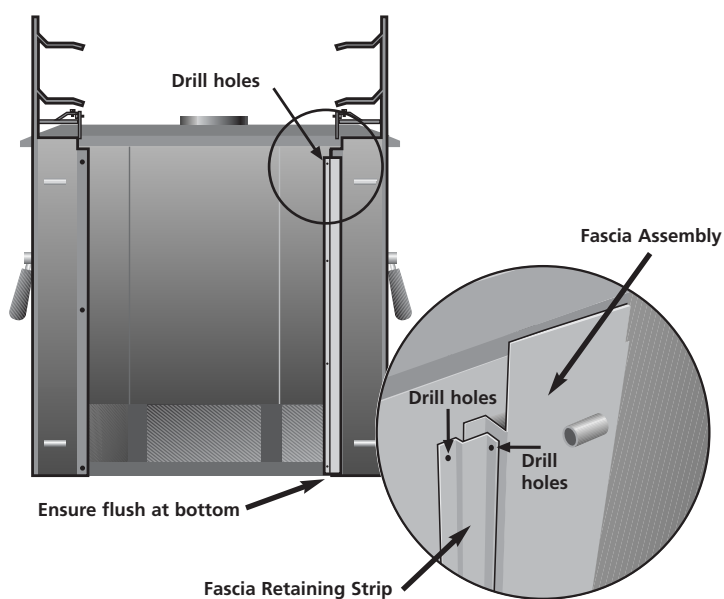

Step 4

1. Attach the other fascia assembly as per steps 2 and 3.
2. Position fascia retaining Strip (Part 6) by placing it along the edge of the Fascia Assembly (See detail). Ensure strip is flush with bottom of heater.
3. Using a 3mm dia drill bit, drill 4 holes through the fascia retaining strip and attach to the side of the heater.
4. Using a 3mm dia drill bit, drill through the other 4 holes in the retaining strip into the fascia assembly.
5. Remove fascia retaining strip from heater and fascia assembly
6. Remove the fascia assembly, and then re-drill the holes in the fascia assembly to 5mm dia using drill bit supplied.
7. Repeat for the other side of heater.
8. Screw fascia retaining strip back into position on both sides of heater

Step 5

Position heater into masonry opening. Ensure it is centrally located and the fascia assembly is hard up against wall.

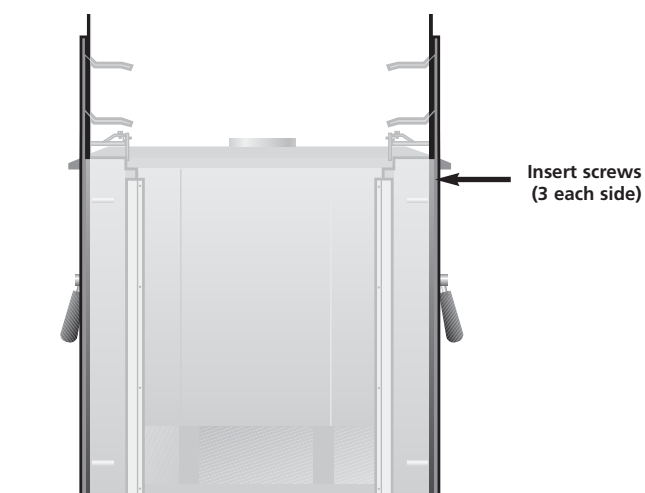

Step 6

1. Attach the fascia assembly removed in Step 4 with screws tightened from the outside of the heater, on both sides of the fascia assembly.

Step 7

1. If required use spray can (Part 4) to touch up if required. Follow directions on spray can.