



33 DVI / Cypress Stone Set Installation Instructions (sku 94700733)

Packing List

- Steel Template
- Pilot Cover Rock (has cut-out on bottom of rock)
- Pilot Shield Rock (has two holes on bottom of rock)
- (16) Standard Rocks (has one hole on bottom of rock)
- Platinum Crushed Glass (in 2-portion bag)
- Bronze Crushed Glass (in 2-portion bag)
- Cobalt Crushed Glass (in 2-portion bag)

Installation Warnings

- **The rocks are fragile, especially after being exposed to heat.**
- Make sure the gas control valve is "OFF" and the heater is cool prior to conducting service.
- Failure to position the parts in accordance with these diagrams or failure to use only parts specifically approved with this appliance may result in property damage or personal injury.
- The burner must be correctly positioned before installing the rocks. Make sure the burner is fully seated and the pilot is properly aligned. See owner's manual for details on burner removal.

HINT: If using propane (LP), convert the appliance before installing the rocks.

HINT: If using optional firebacks, first make the modifications to the burner (see below). After modifying the burner install the firebacks then the stones

Preparing the Burner for Rock Installation

The log set requires the burner to be modified. Remove the two screws holding the ember trays in place (see below). Remove the ember trays.

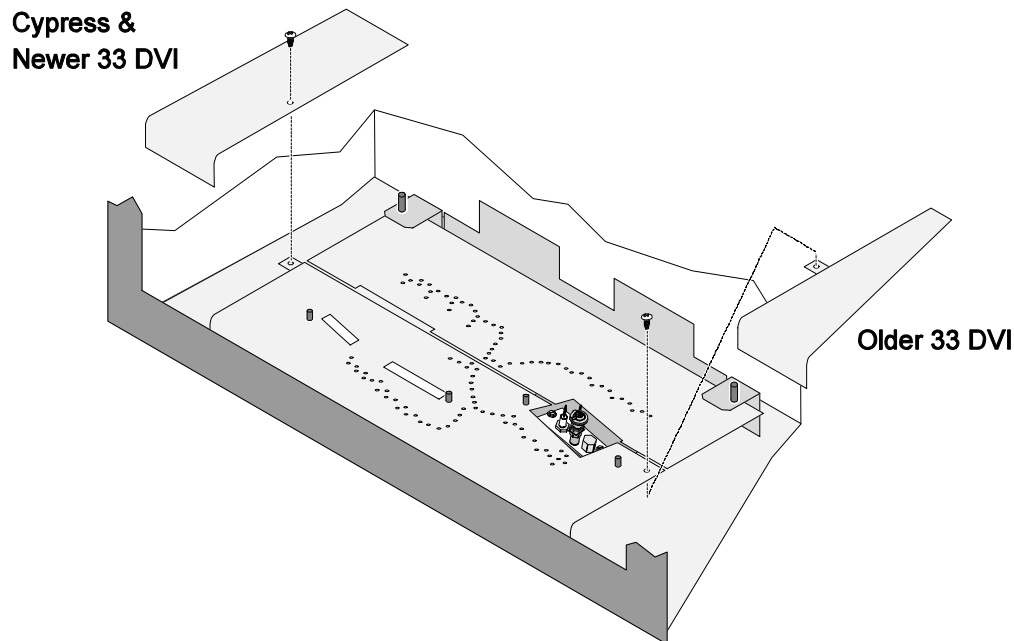



33 DVI / Cypress Stone Set Installation Instructions (sku 94700733)

Preparing the Burner for Rock Installation (continued)

Remove the two screws holding the burner in place (see below). Grasp the burner with both hands and lift it straight up and out of the firebox. Place the burner on a suitable work surface.

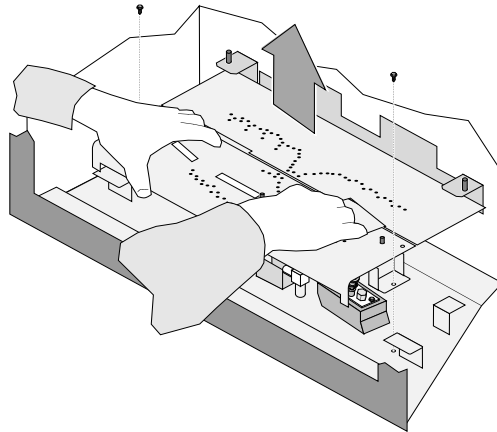

Remove and discard the side air deflector. Replace the screws.

NOTE: On older burners the deflector is riveted in place. Simply bend the extension repeatedly until it snaps off.

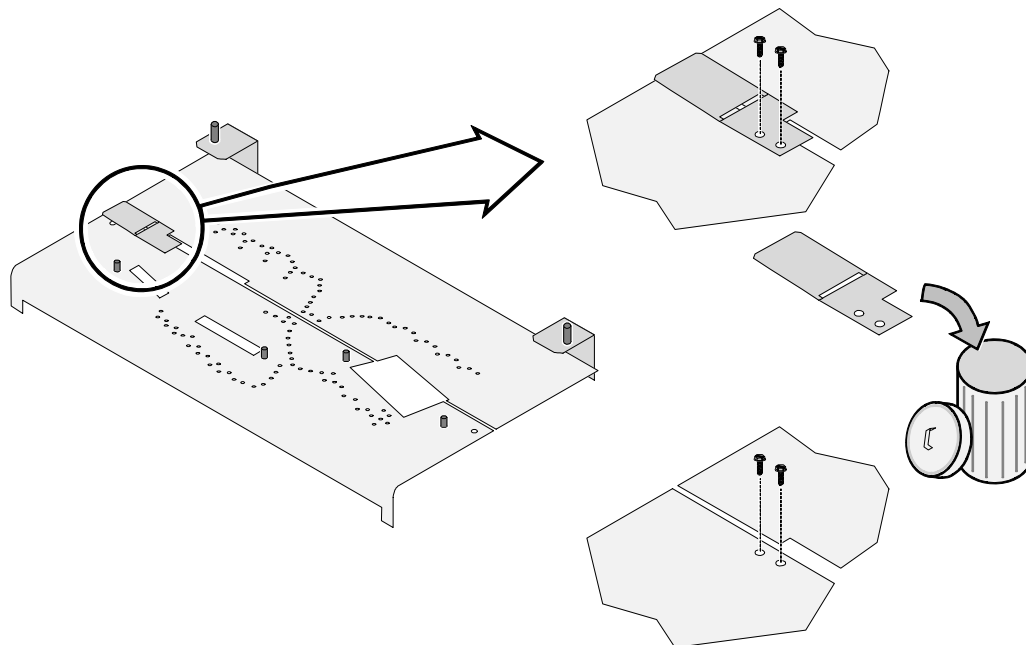



33 DVI / Cypress Stone Set Installation Instructions (sku 94700733)

Preparing the Burner for Rock Installation (continued)

Pilot Shield and Left Log Plate

The Cypress and newer 33 DVI's have a pilot shield and left log plate.

Remove and discard the pilot shield.

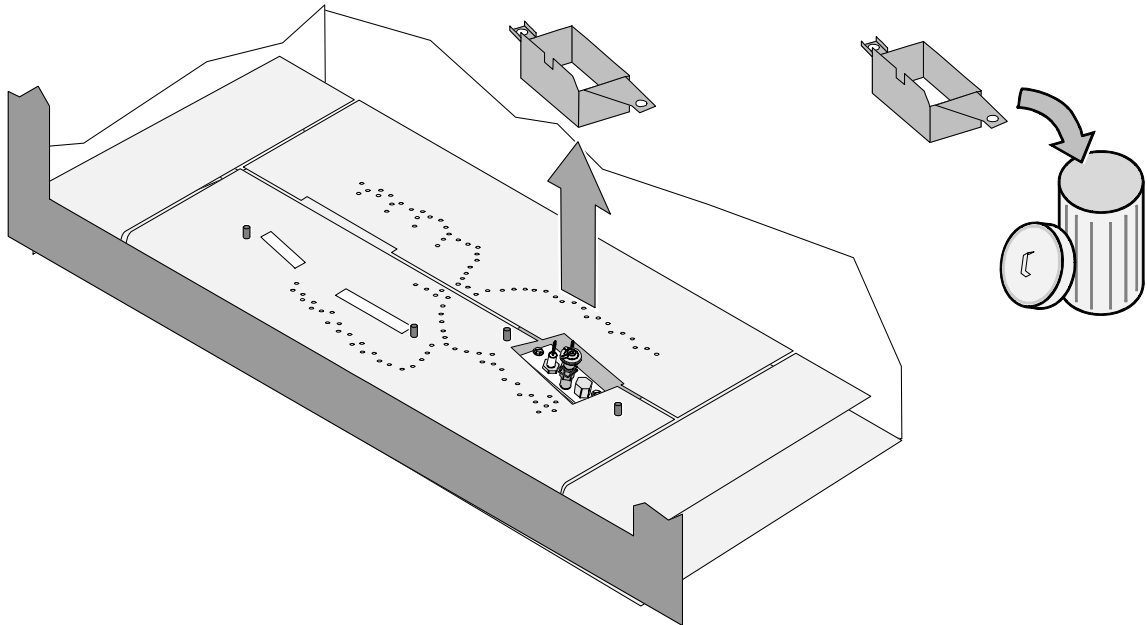

Remove and discard the left log plate.

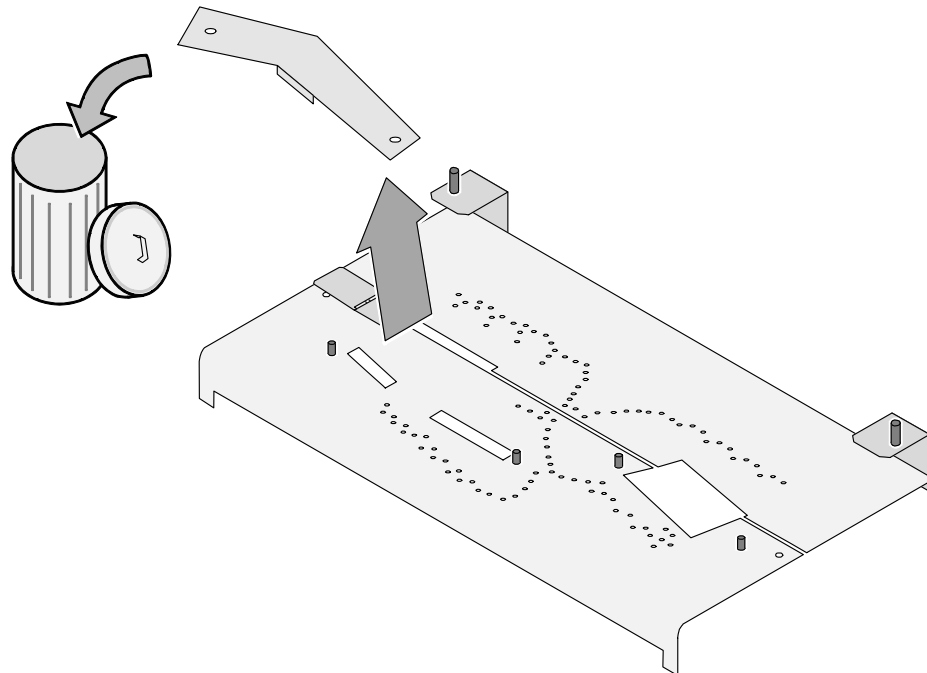



33 DVI / Cypress Stone Set Installation Instructions (sku 94700733)

Preparing the Burner for Rock Installation (continued)

Remove and discard both rear log supports and rear air deflector.

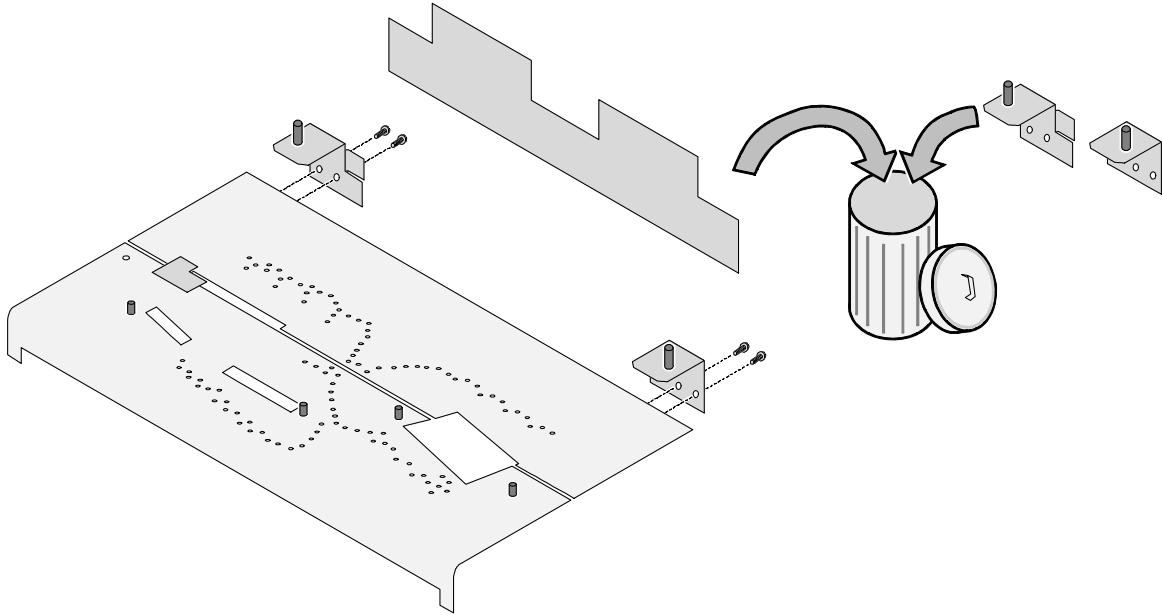

Replace the burner, making sure it is correctly positioned.



33 DVI / Cypress Stone Set Installation Instructions (sku 94700733)

Cypress Only

Remove and discard the fireback shelf/high deflector and install the low deflector (included with the Cypress stove).

FIREBACK NOTE: If using a fireback, do not remove the low deflector. Place the fireback on the low deflector at the rear of the firebox and secure using the upper clips.

Fireback Shelf/High Deflector

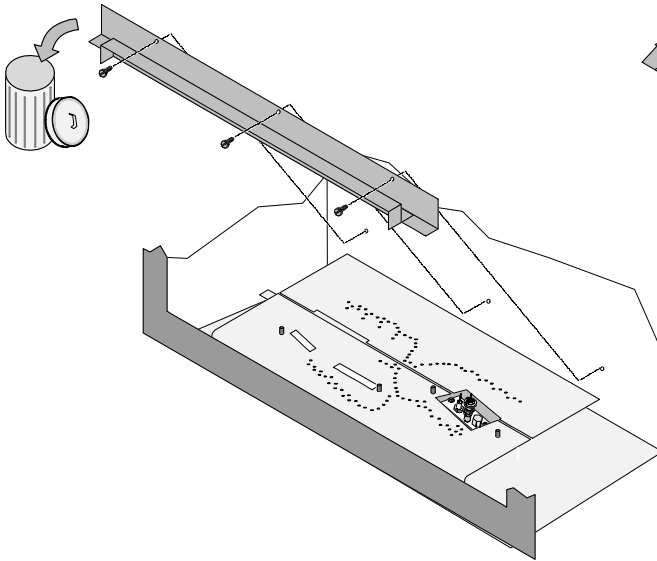

Low Deflector

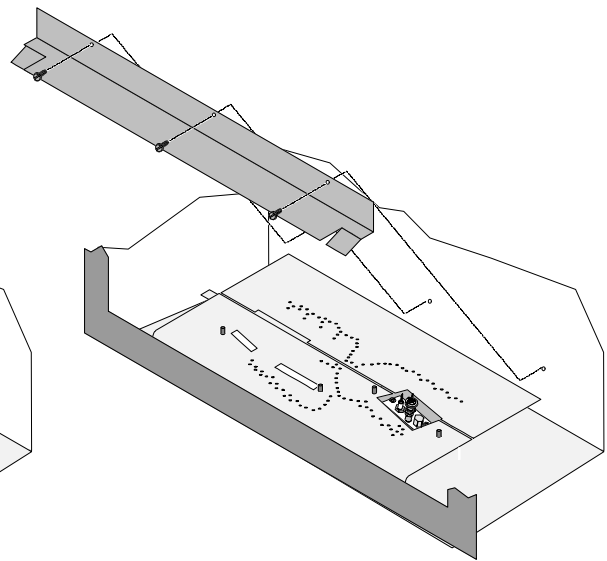

Install the stove pilot shield as shown below.

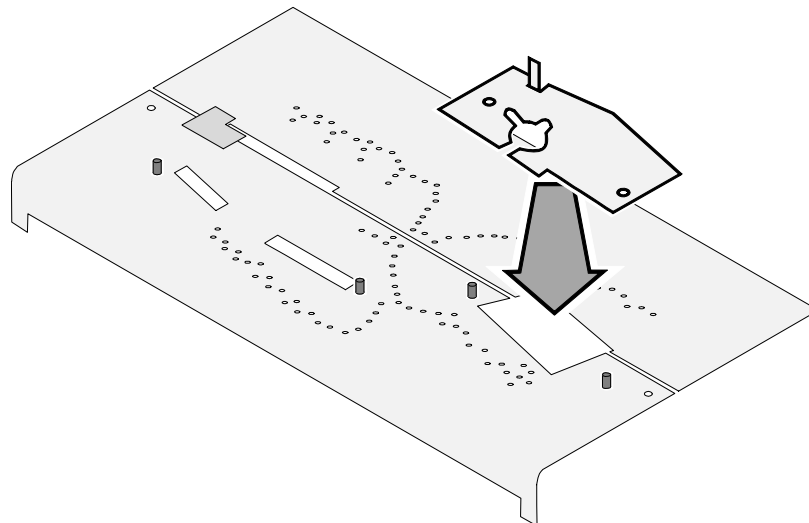

Replace the ember trays and return the stove to the correct configuration.



33 DVI / Cypress Stone Set Installation Instructions (sku 94700733)

Steel Template Installation

The template is shipped with the small tabs bent up. Bend the two large tabs up 90° (see pictures below).

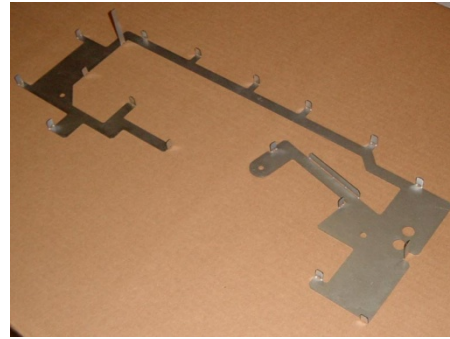
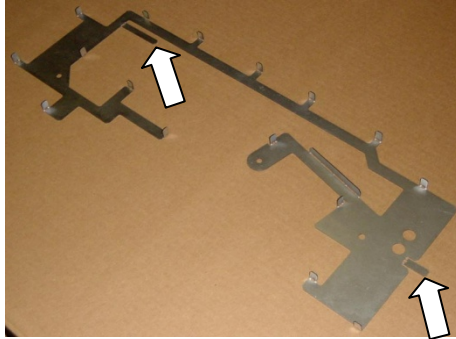

Place the template over the burner as shown below. Note how the template fits over the pins on the burner.





33 DVI / Cypress Stone Set Installation Instructions (sku 94700733)

Pilot Cover Rock and Pilot Shield Rock Installation

There are two unique rocks included with this rock set. One rock covers the pilot, the other shields it. Follow the directions below to install these rocks.

Pilot Cover Rock

Pilot Shield Rock



The pilot cover rock has two holes on one side that fit over the tabs to the left of the pilot. Place the rock as shown below.



The pilot shield rock has two holes that fit over the tabs on the right side of the pilot as shown below.

NOTE: Make sure the rock rests with the larger portion facing forward. When in place the rock will be directly adjacent to the pilot cover rock (see photo below to right).





33 DVI / Cypress Stone Set Installation Instructions (sku 94700733)

Rock Installation

The remaining rocks may now be placed on the burner so the hole on each rock inserts over the pins on the burner. Start with the rocks to the left of the pilot, working your way clockwise around the burner (see photos below).



HINT: When placing the rocks, you may rotate them to achieve an aesthetic look. Pay close attention to rock shading to make sure the rocks appear random.

WARNING: Make sure the rocks are not directly over any burner holes.

HINT: For those rocks that are elevated, you may bend the pin on the template to allow for correct placement.





33 DVI / Cypress Stone Set Installation Instructions (sku 94700733)

Crushed Glass Installation

Three colors of crushed glass are included with this set to allow for different shading options. Each color of glass comes in a two-portion bag (labeled "A" and "B") to accommodate the differences between the 33 DVI and Cypress burner.

33DVI: Use one only the "A" portion of one bag (the larger portion).

Cypress: Use both "A" and "B" portions of one bag.



Pour the crushed glass onto the burner in a thin, uniform layer.

NOTE: Make sure this pin on the burner is concealed by glass.



WARNING: Make sure the glass is a maximum 1 layer thick (NG can be up to 2 layers). If the glass is too thick it will impair burner performance and create soot.

WARNING: Make sure the pilot is not obscured with glass. Clear away glass, if necessary, to insure the pilot flame lights the burner quickly.

